



Transformer Advantage II

Transformer Temperature Monitoring and Control

- Direct Oil Temperature
- Simulated Winding Temperature
- Calculated Winding Temperature (CT Models)
- LTC Temperature Difference (LTC Models)
- NEW** • Three Calculated Winding Temperatures
- Single, Dual and Three RTD Units
- Multi-Stage Fan/Pump Control
- NEW** • Analog and Digital Inputs
- Weatherproof NEMA4X Metal Case
- SCADA Ready – Analog, Digital, DNP3

- Extend Transformer Life
- Maximize Capacity
- Reduce Maintenance

The *Transformer Advantage* is a precision temperature monitor for liquid immersed power and distribution transformers. It is rugged, fully electronic and field configurable. With *Transformer Advantage*, users can extend transformer life, utilize maximum capacity and reduce maintenance costs.

- Up to 11 Setpoint Relays
- Fan Sequencing
- Fan Exercise Timer
- Seasonal Setback

Seven models in the Advantage line offer a range of functions and configurations. All use an accurate and stable platinum temperature sensor (RTD) to precisely measure critical liquid temperatures. Setpoint relays can activate alarms or multiple stages of cooling at different temperatures. A sequencing function equalizes run time between cooling stages. The fan timer can exercise fans at a preset time each day. Seasonal setback is available on any setpoint relay. A front panel test mode quickly verifies cooling and alarm operation. The high current relay contacts can be configured to fail safe (close on monitor fault or power fail).

- Time Stamped Peak Storage
- Front Panel or Remote Setup
- Digital and Analog Outputs
- Alarm Status Display

The large alphanumeric LED display continually shows the selected transformer parameter. Front panel buttons scroll the display through other parameters and relay/alarm status. Peak and valley values for each channel are time stamped and stored in non-volatile memory. These are easily checked and reset by the operator from the front panel or through digital communications. A password-protected supervisor mode accesses all setup parameters. Initial setup can be done from the front panel or through the optional RS232/422/485 digital ports. Windows-based configuration software significantly speeds startup.

- EMI Hardened
- Stress Tested
- Fits Analog Gauge Mounting
- Made in USA

The *Transformer Advantage* is a cost-effective upgrade from analog gauges. It is designed to mount in the existing gauge location and on or in the control cabinet. Probe options fit most popular thermowells, or magnetically mount on units without wells. The *Advantage* has been conservatively designed and stress tested to provide years of trouble free service in the harshest environments. A wide variety of options tailor the *Transformer Advantage* to each application.

Simulated Winding Temperature

This is the traditional method for indicating transformer winding temperature. A heated thermowell, driven by a bushing CT, simulates the winding temperature rise above the oil temperature. This temperature rise is calibrated by the transformer manufacturer at full load. Performance is optimized for steady state or slowly changing loads. The simulated winding method is often used as a direct replacement for an analog winding gauge when higher accuracy, more configuration flexibility or a SCADA interface is required. One, two and three channel Advantage models support this method on new or existing transformers.

Calculated Winding Temperature

A newer method uses oil temperature and load current to calculate winding temperature, based on IEEE guidelines. The Transformer Advantage analyzes transformer parameters to determine thermal time constants for the oil and windings. These time constants are changed dynamically based on load and cooling conditions. Rate of change information is also utilized in the Weschler CT algorithm to further improve the winding temperature accuracy. This is particularly important when operating above nameplate rating. Three Advantage models use the CT method for winding temperature indication.



**WESCHLER
INSTRUMENTS**
DIVISION OF HUGHES CORPORATION

**16900 FOLTZ PARKWAY
CLEVELAND, OHIO 44149**
Phone: (440) 238-2550 Fax: (440) 238-0660
www.weschler.com Email: sales@weschler.com

Transformer Advantage

Typical Configurations

Advantage SC

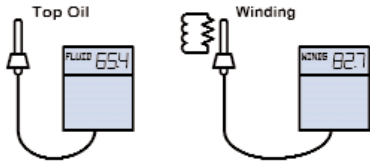

Advantage DC

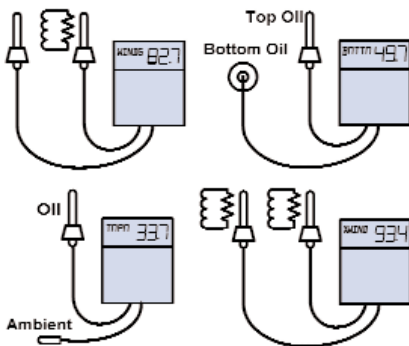

Advantage TC

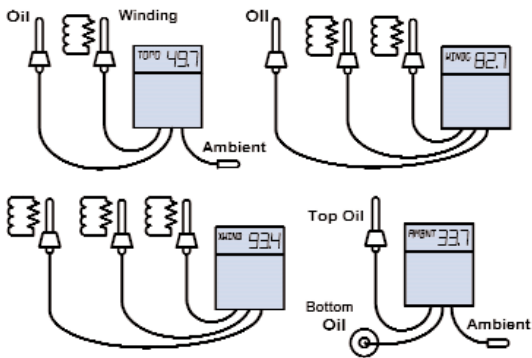

Advantage CT

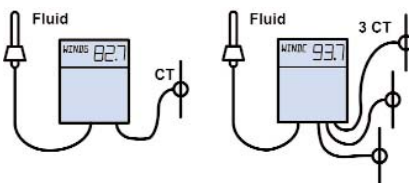

Advantage CTX

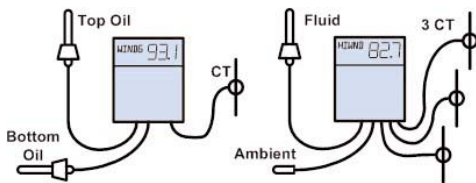

Advantage CT/LTC

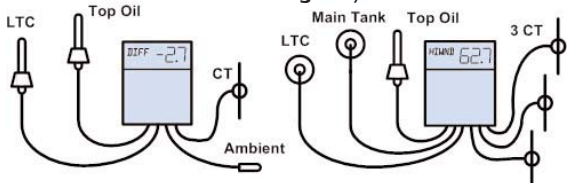

Simulated Winding Models

Advantage SC

The single channel Advantage SC directly measures one liquid temperature using either an RTD probe installed in a thermowell or a magnetic probe mounted on the side of the tank. The display prompt can be set to Top Oil, Fluid, Winding, HWinding, YWinding, XWinding, Ambient, or Bottom Oil. Winding temperature is simulated by using the RTD probe in a heated thermowell. Full scale temperature can be set to either 200°C or 250°C. During setup, each form B or form C setpoint relay is individually configured to activate at different values of the measured temperature, time of day or a remote command. Hysteresis, non-alarm state and sensor fail response are also individually settable. Analog output and up to eleven setpoint relays are available in the SC model.

Advantage DC

The Advantage DC provides two channels of temperature monitoring in a single unit. Any mix of thermowell probes and magnetic probes can be used. Each setpoint relay can be configured to trigger on channel 1 or channel 2 temperature, time of day or a remote command. Both channels can be retransmitted using the multi-channel analog output option. With all the setup flexibility of the Advantage SC, one Advantage DC easily replaces the oil and winding gauges on an existing transformer.

Advantage TC

The Advantage TC provides three identical channels to measure any combination of top oil, bottom oil, winding and ambient temperature. One Advantage TC can monitor oil and two winding temperatures. The ambient probe coupled to a setpoint relay can be used for a low temperature alarm or pump lockout. Three channels of analog output, with adjustable span, are available.

Calculated Winding Models

Advantage CT

The Advantage CT model directly measures transformer oil temperature and transformer load current in one phase. Winding temperature is calculated from the measured current, liquid temperature and key transformer parameters. This calculation uses a proprietary algorithm based on IEEE C57.90. The sophisticated algorithm also provides different thermal profiles for natural, forced or directed oil cooling. An existing current transformer can be wired directly to the Advantage CT, or the clamp-on option can be ordered to avoid CT loop rewiring. With the Polyphase Current option, currents in three equal windings are compared and the highest value used for the winding temperature calculation. A new 3 winding option displays separate temperatures, based on each winding's characteristics. One or three channels of analog output readback oil temperature, winding temperature and/or load current. Auxiliary analog/digital inputs allow the Advantage CT to monitor cooling circuits or other transformer signals.

Advantage CTX

The Advantage CTX adds an extra temperature channel to the capabilities of the Advantage CT. This channel is typically used to monitor ambient or bottom oil. Many control and alarm schemes are possible with up to 9 form C or 6 form C and 5 form B relays.

Advantage CT/LTC

This top end model in the Advantage line combines the functions of the CT and LTC models in one unit. For a Load Tap Changer with a thermowell, the main tank (top oil) probe is used as a reference for both calculated winding temperature and Load Tap Changer temperature differential. The third temperature input is available to monitor ambient or bottom oil. For an LTC without a thermowell, this input is used with an additional magnetic probe on the main tank as an LTC reference.

Transformer Temperature Monitoring & Control

Advantage LTC

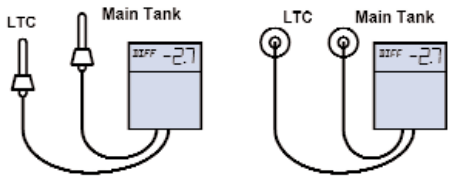

Advantage LTC

The Advantage LTC helps extend maintenance intervals and reduce the incidence of transformer failure due to Load Tap Changer problems. The Advantage LTC measures main tank and Load Tap Changer tank temperatures. Both a difference and deviation (difference trend) are calculated to detect contact wear, misalignment, coking, overloading, locked rotor and other heat generating conditions. Because LTC degradation is a long-term effect, sophisticated digital filtering techniques and a proprietary LTC tailoring function are used to avoid false alarms from short-term changes. Best accuracy is achieved with thermowell probes in both the main and LTC tanks. For LTCs without a thermowell, magnetic probes are mounted on both tanks.

Specifications

Temperature Inputs:

Sensor: 3 or 4 wire, 100Ω Platinum RTD, $\alpha=0.385$;
4 wire Class A probes supplied.
Range: -70.0 to 250.0°C
Display Resolution: 0.1°C
Display Accuracy: $\pm 0.5\%$ of full scale with thermowell probe,
 $\pm 1.0\%$ with magnetic probe

Current Inputs:

Direct CT Input: 1-10A full scale, 50/60Hz, burden $<0.1\Omega$
Clamp-on CT Input: 1-20A full scale, 50/60Hz
Donut CT Input: 1-10A full scale, 50/60Hz
Display Resolution: 1A of load current
Display Accuracy: 1% of full scale

Auxiliary Analog/Digital Inputs:

Configuration: 5 differential inputs with shared ground
Input Ranges: 5/150/300V, 1/20ma AC or DC;
5VDC for dry contacts
Display Resolution: 5 digits

LED Displays:

Prompt: 5 digit, 14 segment red alphanumeric,
0.5" (13mm) height
Value: 5 digit, 14 segment red alphanumeric,
0.8" (20mm) height

Setpoint Alarms & Relays (individually settable):

Setpoint Range: -40.0 to 250.0°C
Hysteresis: 0-20°C
Non-Alarm State: User selectable energized or de-energized
Source (Enhanced Version):
SC Ch1, Aux1-8, Time, Remote
DC Ch1, Ch2, Aux1-8, Time, Remote
TC Ch1-3, Aux1-8, Time, Remote
CT Oil, Winding1-3, Hottest Winding, Load1-3,
Highest Load, Aux2-8, Time, Remote
CTX Oil, Ch2, Winding1-3, Hottest Winding, Load1-3,
Highest Load, Aux2-8, Time, Remote
LTC Main Tank, LTC, Differential, Deviation, Aux1-8,
Time, Remote
CT/LTC Oil, Winding1-3, Hottest Winding, LTC, Diff, Dev, Ch3,
Load1-3, Highest Load, Aux2-8, Time, Remote

Sensor Failure:

Detection: Open probe, shorted probe or internal failure
Operation: Enhanced version: Any setpoint relay can be used as
a sensor fail relay. Regular version: Relay 8 only
Sensor Fail Response: Energize, De-energize

Contact Ratings:

(all relays)
10A @ 125Vac
10A @ 240Vac
1/2HP @ 120/240Vac
10A @ 30Vdc, 1A @ 125Vdc
Contact Protection: MOV (250V, 6500A)

Power Requirements:

120V AC	11VA	32V DC	0.3A	125V DC	0.12A
240V AC	14VA	48V DC	0.25A	250V DC	0.09A
		110VDC	0.2A		

Peak / Valley:

Stores min & max reading for each measured or calculated channel. Data stored with time stamp in non-volatile memory (30 day capacity in hourly mode).

SCADA Communications:

Port 1 RS-232 only
Connection: Internal RJ-11 or RJ-12
Port 2 RS-232, RS-422 or RS-485 (2 or 4 wire)
Connection: Screw Terminals on I/O Module
Analog Retransmit
Range: User settable zero and full scale between 0 and 24ma dc
Span: User adjustable from -40 to 250°C
Accuracy: $\pm 0.5\%$ of Display
Source: Same as setpoint relays (except Aux Inputs & Dev not included)
Voltage: 24V max.
DNP3 (option) Level 1 slave
Fiber Adapter (option) 8" cable converts Port 1 to RJ12 male with 5V@20mA power for fiber optic converter
Fiber Transceiver (option) 850 nm LED drives multimode fiber at up to 57600 baud. ST connector; ASCII or DNP3 protocol

Environment:

Operating Temperature: -40 to 70°C (-55°C with heater)
Storage Temperature: -40 to 85°C
Memory Retention: Setup parameters - indefinite
Clock - 5 days
Enclosure Protection: NEMA 4X (IP66 dust & water)
EMC: EN 61326:1997
Surge: IEEE C37.90.1-1989
Enclosure: Epoxy coated aluminum, 13lbs (5.9kg)
Surface Mount: 8.3"W x 13.4"H x 7.6"D (211x340x193mm)
Thru Panel Mount: 8.0"W x 13.2"H x 6.5" behind panel (204x335x165mm)
Fittings: Two 1" conduit holes; 1, 2 or 3 RTD grips.
Optional SO cable fittings available

Warranty:

5 years

Subject to change without notice. See specific product manual for detailed specifications and notes.

Transformer Advantage_{II} is Weschler's third generation digital temperature monitor for power plant and substation applications. Since the first model was introduced in 1996, we have continually enhanced the features and the performance of our IED line. The new **Transformer Advantage_{II}** builds on this experience to offer more models, more configuration options, a more sophisticated winding temperature algorithm and DNP3.0 communications. With field reliability proven in thousands of installations worldwide, we confidently offer a five year warranty.

Transformer Advantage Configuration Guide

PART NUMBER (SEE BOTTOM OF PAGE FOR EXAMPLE)

Certain combinations of options are not available on all models. Call for configuration & application assistance.

<p>SERIES G = Transformer Advantage</p>	1st Probe	2nd Probe
<p>MODEL 3 = Advantage SC 4 = Advantage CT 5 = Advantage CTX 6 = Advantage LTC 7 = Advantage DC 8 = Advantage CT/LTC 9 = Advantage TC</p>		
<p>VERSION R = Regular (not available on LTC model) E = Enhanced</p>		
<p>SETPOINT RELAYS D = 2 Form C E = 4 Form C 5 = 5 Form B & 1 Form C F = 8 Form C^ G = 5 Form B & 5 Form C^ S = Special</p>		
<p>4 WIRE RTD PROBES [2 digits] Stainless, Well Mount (specify adapters): 1 = 12" long, 3/8" dia 12' cable (3.6m) 2 = 12" long, 3/8" dia 25' cable (7.2m) 4 = 18" long, 3/8" dia 25' cable 5 = 8" long, 3/8" dia 25' cable F = 8" long, 3/8" dia 50' cable G = 12" long, 3/8" dia 50' cable B = Two 12" long, 3/8" dia 12' cable C = Two 12" long, 3/8" dia 25' cable D = Two 8" long, 3/8" dia 25' cable E = Two 8" long, 3/8" dia 50' cable T = TR02 probe/heater replacement, 8.13" x 1.7" dia, w/adaptor & 25' cable Magnetic, Surface Mount (no adapters req'd): 6 = 4" dia 25' cable 7 = Two 4" dia, each w/ 25' cable 8 = 4" dia w/weather cover & 25' cable 9 = Two 4" dia, w/weather covers & 25' cables A = Ambient Sensor w/25' cable & bracket (no adapter req'd) S = Special probe X = Not required</p>	Longer cables available on special order	
<p>CT INPUT [2 digits] nn = full scale, % of 10 Amp [use 00 for 100%] example: 50 = 5 Amp full scale SA = >10 Amp (specify value) SP = <1 Amp or special XX = not required (SC, DC, TC & LTC models)</p>		
<p>POWER U = 102-138VAC, 103-148VDC (120VAC/125VDC nominal) T = 204-276VAC, 205-288VDC (240VAC/250VDC nominal) W = 90-264VAC, 85-300VDC, 39-57VDC R = 90-264VAC, 85-300VDC, 24-40VDC P = 24-40VDC (32V nominal) 9 = 39-57VDC (48V nominal) S = Special</p>		

MISCELLANEOUS OPTIONS [3 digits]**

- B = Thru Panel mount
- D = Substitute donut CTs for clamp-on CTs
- V = Auxiliary setpoint relay (Form C)
- H = 120/240VAC Heater for -55°C ambient
- N = Sunshade for display
- R = Two SO cord fittings (0.6-0.7" dia)
- T = Fiber Optic Transceiver & Adapter Cable } digital or DNP3 output required
- F = Fiber Optic Adapter Cable
- S = Special
- X = None

INPUT OPTIONS

	CT	Analog/Digital Inputs				
		None	Two	Five	Seven	Eight
One winding temperature	None ^a	X	2	K	-	8
	Direct	X	2	K	7	-
Three winding temperatures	Clamp-on	C	4	Q	Y	-
	Direct ^a	P	W	L	-	-
High winding temperature	Clamp-on ^a	J	U	M	-	-
	Direct ^a	3	-	-	-	-
	Clamp-on ^a	D	-	-	-	-

Shaded options require Enhanced version S = Special

THERMOWELL PROBE ADAPTERS*

Thread	Well ID
1 = 7/8" UNF	0.385"
A = 7/8" UNF	7/16"
E = 7/8" UNF	0.490" (12.5mm) or 1/2"
3 = 7/8" UNF	5/8" or 16mm
4 = 1/2" NPT	0.385"
B = 1/2" NPT	7/16"
F = 1/2" NPT	0.490" (12.5mm) or 1/2"
6 = 1/2" NPT	5/8" or 16mm
7 = 3/4" NPT	0.385"
C = 3/4" NPT	7/16"
G = 3/4" NPT	0.490" (12.5mm) or 1/2"
9 = 3/4" NPT	5/8" or 16mm
S = Special (mixed or other sizes)	
U = Universal kit (3 fittings & 3 sleeves)	
X = None	

SCADA OUTPUTS***

- A = Analog (single channel)
- C = DNP3 Digital (RS-232/422/485)
- D = Digital (RS-232/422/485)
- E = Analog (single channel) & Digital
- F = Analog (single channel) & DNP3
- M = Analog (3 channels)^a
- N = Analog (3 channels w/ch-ch isolation)^a
- P = Analog (3 channels) & Digital^a
- R = Analog (3 channels, isolated) & Digital^a
- T = Analog (3 channels) & DNP3^a
- U = Analog (3 channels, isolated) & DNP3^a
- S = Special
- X = None

^a Requires one of the 3 available option slots. [†] SC, DC, TC & LTC models
 * One adapter for each probe.
 ** If more than 3 of the listed options are required, order additional items separately.
 *** Single channel analog not available on CT/LTC & TC; Digital or DNP3 required on Enhanced version.

PART NUMBER EXAMPLE:

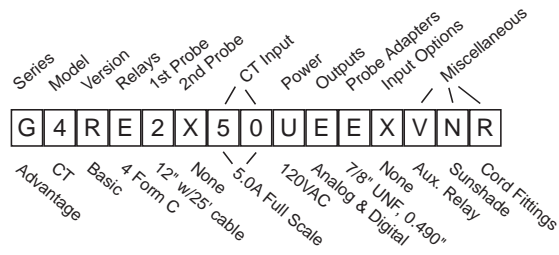

For PC connection to RS-232 port, order 10' adapter cable #1000001701.

THERMOWELL PROBE:

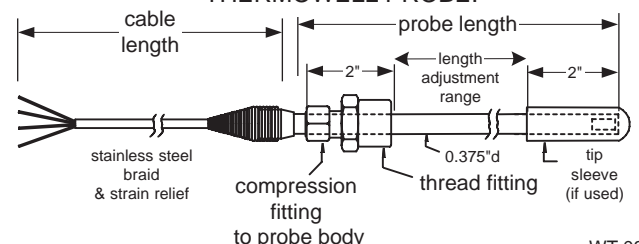

WT-02 2/08

Transformer Advantage - Enhanced Version

The Enhanced Version includes a number of new capabilities to expand the usefulness of the Transformer Advantage.

Alarms & Relays

In the Regular version (code R in the third digit of the part number), each setpoint alarm is tied to the corresponding relay. The number of available alarms equals the number of installed relays. A more flexible arrangement in the Enhanced version (code E in the third digit of the part number) separates alarms and relays. Each Enhanced Advantage has 12 alarms, regardless of the number of relays. More than one alarm can be assigned to a relay. A relay is activated by any of the assigned alarms. Fewer relays are needed and field wiring is simplified.

To control the timing of relay operation, each enhanced alarm includes settable pickup and dropout delays (1-300 sec). This feature reduces momentary equipment activation or false alarms due to transient conditions. Each alarm still has adjustable setpoint and hysteresis. The setpoint includes a seasonal setback option. The alarm source can be any measured or calculated channel, a digital command, time of day or calendar trigger.

The Enhanced version is available in all Advantage models. The Regular version is available in all models, except LTC. Relay operation in both versions includes the ability to 1) sequence fan operation to equalize run time and equipment wear, 2) select the non-alarm relay state [coil on or coil off], 3) define relay action when a sensor or equipment failure is detected.

Sensor Fail Alarm

One sensor fail alarm/relay (#8) is included in each Regular version Transformer Advantage. The sensor fail alarm operates when a sensor failure or internal circuit failure is detected. It activates the sensor fail relay and any other relay that has its sense fail function enabled. The sensor fail relay can be set to either energize or de-energize on a fault condition. One sensor fail relay is provided in addition to the number of setpoint relays ordered.

The Enhanced version also includes the additional relay for the sensor fail function (#8). However, any alarm can be defined as a sensor fail alarm. More than one alarm or relay can be used for sensor fail detection to provide redundancy or additional control capability. Pickup and dropout delays can be set to inhibit false trips due to momentary conditions.

CT Ratio Entry

The Enhanced version provides two methods to set up a CT input on the CT, CTX and CT/LTC models. If the transformer's CT ratio is known (e.g. 2000:5), this can be directly entered into the Advantage during initial configuration. For situations where the CT ratio is not known, or the ratio accuracy is suspect, the CT input can be calibrated precisely using a DMM.

Three Winding Temperatures

The Regular version of Calculated Winding models (CT, CTX, CT/LTC) accepts one maximum current entry and one temperature gradient set (for ON and OF or OD, if applicable). One winding current and one winding temperature value are displayed.

The High Winding option can be used on transformers with three equal windings. This option has three CT inputs but only one CT ratio and only one gradient set. The Advantage selects and displays the winding current from the highest phase. It calculates and displays the winding temperature on that phase, but provides no data on the other loads or temperatures.

While both these configurations can be ordered with the Enhanced

version, a new three winding option is only available on the Enhanced version. It inputs and displays the current from three windings. Three winding temperatures are calculated and displayed. Individual gradient and CT values are entered for each winding, allowing use on any type of transformer.

In addition to displaying individual winding values, the Advantage with a three winding option also displays the highest winding current and highest winding temperature. These parameters can be used as alarm sources. This reduces the number of alarms needed to control for typical configurations, such as 'activate fans when any winding reaches 80°C'. Highest winding current and highest winding temperature can also be read through the digital and analog outputs.

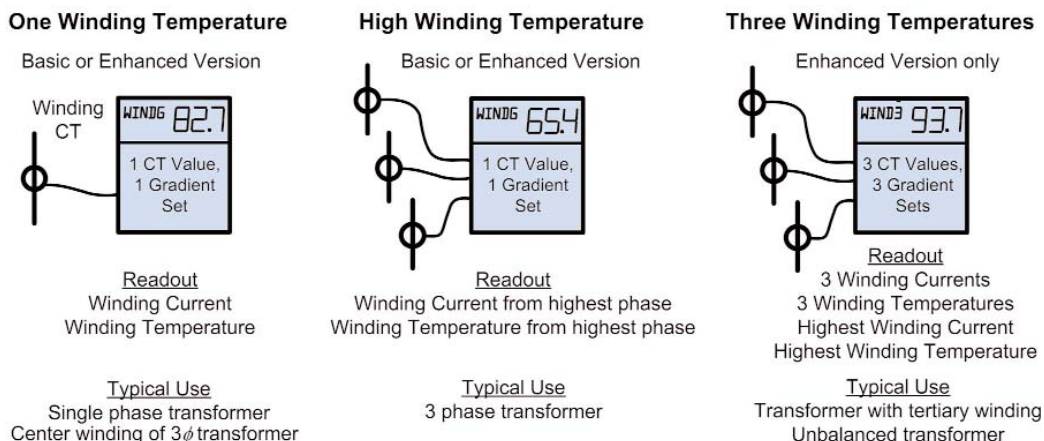

Transformer Advantage - Monitoring & Control

Auxiliary Inputs

Additional analog/digital inputs are available on the Enhanced version of any Transformer Advantage. These inputs handle AC or DC voltages from 5 to 300V full scale, DC current of 1 or 20mA full scale and dry or wet switch contacts. Each input is separately adjusted for function and range. One alarm is provided with each auxiliary input. This is in addition to the 12 general setpoint alarms. Each auxiliary alarm has programmable high and low limits, hysteresis, pickup delay and dropout delay. The alarm is linked to a setpoint relay for control of external equipment. It can also be configured to enable its operation only when another relay is activated. This allows more complex control schemes.

AC voltage inputs can be used to confirm that fans and pumps are running normally. A current transducer (ACA to ACV) provides isolated sensing of the motor current. High and low alarm limits on each channel are adjustable to distinguish a tripped breaker, freewheeling blade or overloaded motor. A relay can be activated for remote monitoring or control. The operating value and alarm status are sent to the substation network through the digital interface.

Auxiliary DC inputs allow the Advantage to monitor the output from legacy analog gauges on the transformer. These typically have low voltage or current loop outputs. The Advantage acts as a data concentrator, sending their values through the digital interface to the substation network. The Advantage will also activate alarms and relays from these signals.

External switches or on/off signals can also be read through the auxiliary inputs. Either dry or wetted switch contacts are compatible. For dry (unpowered) contacts, the Advantage supplies 24V DC power.

Up to eight auxiliary inputs can be ordered on SC, DC and TC models. This is reduced on the Calculated Winding models by the number of winding current inputs. Seven auxiliary inputs are available with a single winding input and five are available with three winding inputs.

Software Support

Individual Windows-based Configuration and Monitor programs are available for each model in the Regular version Advantages. These programs speed installation and simplify field support. Setup entries are made by clicking various menu items and entering selected parameter values. The resulting file can be downloaded to the Advantage or saved for later use. The Monitor program provides a quick snapshot of measured values, alarm settings and relay status. The program can also test the operation of selected relays.

All Enhanced version models are covered in one combined Configuration/Monitor program that is compatible with Windows 95-2000, XP & Vista. A launch pad window selects the model, address and application. The software supports direct PC serial ports and the higher addresses (7-16) used by many USB to serial adapters. A password lockout prevents unauthorized changes to a unit's configuration.

Either type of Configuration program can be used to build and save a setup file without connecting to the Advantage. This reduces the field installation time. Weschler will also, at no charge, review a configuration file and preload it to an Advantage before shipping.

Every Advantage digital interface includes two ports: a hard-wired RS-232/422/485 port and a plug-in RS-232 port for field service. An adapter cable is available to tie the plug-in port to a PC serial port. The fiber-optic transceiver option is compatible with 850nm multimode fiber. It mates to a standard ST connector. The ASCII protocol communicates with the Advantage software and popular RTUs. The optional DNP3 protocol can be used over wire or fiber connections. Units with DNP3 also respond to ASCII commands.

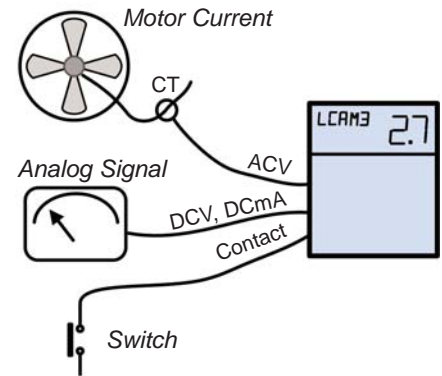

Example: Fan Current Monitor

Connect a clamp-on current transducer (50A AC input, 5V AC output) to the fan motor activated by an Advantage setpoint relay (e.g. relay 1). Wire the transducer to an auxiliary input channel. Set the channel hardware to 5V full scale. Configure the corresponding auxiliary input alarm to 50A AC full scale. Set the low and high alarm limits to accommodate the normal running current of the fan motor. Associate this alarm with relay 1, so it is enabled only when the fan relay is activated. Use a 10 second pickup delay to inhibit false alarms due to motor starting current. Link the fan alarm to another Advantage relay to activate a remote warning indicator.

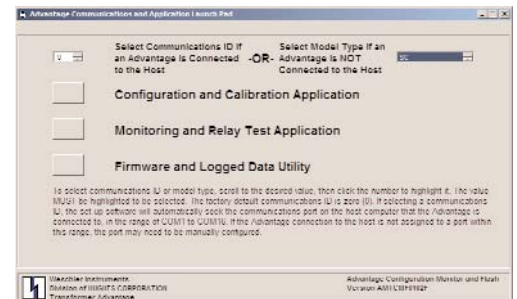

16900 Foltz Parkway
Cleveland OH 44149 USA
Phone: (440) 238-2550 Fax: (440) 238-0660
Email: sales@weschler.com
www.weschler.com