

WESCHLER INSTRUMENTS

DIVISION OF HUGHES CORPORATION

OWNERS MANUAL

for

BG Series

REVISION 2.7 6/11

16900 Foltz Industrial Parkway, Cleveland, Ohio 44149

Phone: 440-238-2550 Fax: 440-238-0660

Email: sales@weschler.com

Contents

1 INTRODUCTION	1
2 FEATURE DESCRIPTIONS	2
BarGraph Protection	2
Bar Display	2
Digital Display	2
Trend Indicators (Option)	3
Setpoints (Option)	3
Temperature Measurement	4
Hysteresis	4
Retransmit (Option)	4
Peak/Valley (Option)	4
Power	4
3 INSTALLATION	5
Verification	5
Mounting	5
Electrical Hookup	6
4 SETUP	7
Normal Display Operation	7
Display Operation During Setup	7
Operator and Supervisor Setup	8
4.1 OPERATOR SETUP PROGRAMMING	9
Activating Operator Setup	9
Operator Setup Actions	9
Alarm Setpoints	10
4.1.1 FAILSAFE SETPOINT SETUP PROCEDURE	11
High Setpoint	11
Low Setpoint	11
4.2 SUPERVISOR SETUP PROGRAMMING	12
Activating Supervisor Setup	12
Supervisor Setup Functions	12
Alarm Setpoints	14
Enable/Disable Peak/Valley	15
Set Hysteresis	15
BarGraph™ Zero	16
BarGraph™ Full Scale	16
Set Barform	17
Enable/Disable Operator Setup	18
Set Decimal Point	18
Set Bar Zero	19
Set Bar Full Scale	20
Set ID	20

5 CALIBRATION	21
Calibration Procedure	21
6 TEMPERATURE MEASUREMENT	24
7 ANALOG RETRANSMIT OPTION	25
Analog Retransmit Output Options	25
7.1 ANALOG RETRANSMIT CALIBRATION	26
7.2 ISOLATED ANALOG RETRANSMIT CALIBRATION	27
8 PEAK/VALLEY OPTION.....	29
Valley Display	29
Valley Capture Cycle	29
Valley Reset	29
Peak Display	29
Peak Capture Cycle	29
Peak Reset	29
9 REPLACEMENT PARTS.....	30
10 WARRANTY	31
Appendix I - BARGRAPH RETROFIT GUIDE	32
Appendix II - TERMINAL CONNECTIONS	33
BG-252, BH-252, BD-101, PC-101, PH-101, PG-101 & PG-202	33
BG-241, 251, 261 & 281	34
Terminal Barrier Strip Option (BG-241, 251, 261 & 281)	35
Line Frequency and Synchroscope (BG-241, 251, 261 & 281)	36
Wattmeter Wiring (BG-241, 251, 261 & 281)	37
Varmeter Wiring (BG-241, 251, 261 & 281)	38
Power Factor Meter Wiring (BG-241, 251, 261 & 281)	39
RS-485 Communications Cabling	40
Appendix III - SPECIFICATIONS	41
Appendix IV - CIRCUIT BOARD LAYOUT DRAWINGS	42
BG-252, BH-252, BD-101, PC-101, PH-101, PG-101 & PG-202	43
BG-241, 251, 261 & 281	44
Option 4 Module (Isolated Analog Retransmit)	45
Appendix V - PHYSICAL DIMENSIONS.....	46
BG-241, 251, 261 & 281	46
BG252	47
PC-101 and PC-202.....	47

1 INTRODUCTION

Weschler Instruments offers a complete line of BarGraph™ instruments that fit many existing analog meter cutouts (see Appendix I) and can operate with the same input signals. They provide enhanced features, such as peak/valley hold, retransmit, computer communication, plus multiple bar and digital display colors and combinations to meet customer-specific engineering considerations. Detailed specifications are listed in Appendix III.

This manual covers the following standard BarGraph models from Weschler Instruments:

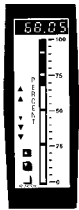

BG-252 6" Vertical BarGraph (pictured)
BW-1316 6" Vertical BarGraph
PG-101 10" Vertical BarGraph
PC-101 DIN (72 X 144 mm) Vertical BarGraph

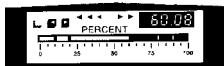

BH-252 6" Horizontal BarGraph (pictured)
PH-101 DIN (72 X 144 mm) Horizontal BarGraph

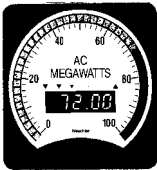

BG-241 4 1/2" Square BarGraph
BG-261 8 1/2" Square BarGraph (pictured)

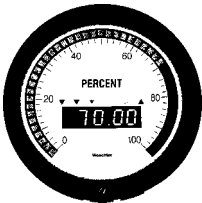

BG-251 6" Round BarGraph
BG-281 8" Round BarGraph (pictured)

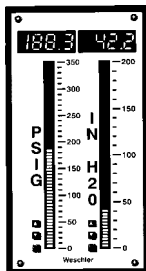

PC-202 DIN (72 X 144 mm) Dual Vertical BarGraph (pictured)
ML-202 DIN (72 X 144 mm) Dual Vertical BarGraph
PG-202 10" Dual Vertical BarGraph

2 FEATURE DESCRIPTIONS

BarGraph Protection

Weschler BarGraphs are internally protected against power and input surges. The power supply integrates a fuse and MOV to insure that no circuit damage occurs. Input surges are virtually eliminated by internal CTs and PTs (for AC) and a clamping circuit (for DC). For maximum limits, see Appendix III, Specifications.

When measurements such as Retransmit and Communication are read from the BarGraph, the outputs are directly driven. The user should provide safeguards to prevent ground loops when using these options.



Warning: Review Section 3, Installation, to insure that the proper inputs and options were ordered and received. Connecting a BarGraph in the wrong application may cause damage to the instrument!

Bar Display

The bar display consists of either 51 segments (PG-101 and PG-202) or 101 segments (all others). The segments are either red (standard) or green (optional). Multi-color and amber bar displays are also available.

The zero point can be set so that the bar scale begins indicating anywhere from the bottom to the top of the instrument. The zero can also be set to a location that is not visible on the bar, to allow an expanded indication. For process applications where the zero point could vary, simple programming can give the user selections of 25%, 33%, 50%, or 100% from the bottom of the bar scale. Typical applications that require an elevated zero point are: center frequency deviation (center zero - 50%), vacuum measurements (25% and 33%), and mineshaft and elevator location (top zero - 100%).

Digital Display

The BarGraph can be combined with a seven segment, 3-1/2 digit (-1,999 to 1,999) or 4-1/2 digit (-19,999 to 19,999) LED digital display to increase usefulness and instrument resolution. The digital display is a dynamic option of the BarGraph since all readings can be in direct or engineering units related to any input signal. The analog trend on the bar graph can be seen at a glance, but when critical measurements or fine tuning are required, the digital display has a resolution of up to 0.01%.

The standard color for the digital display is red, with green or amber available as options.

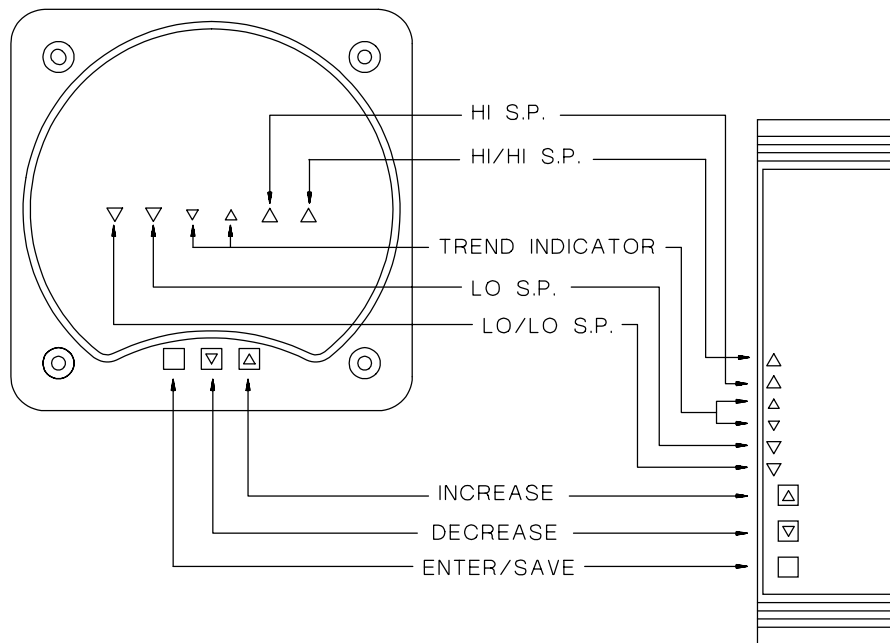

Trend Indicators (Option)

The BarGraph provides visual indication of the process signal direction. The annunciator arrows on the front of the BarGraph are red or green LEDs that respond to changes in input signal at a rate corresponding to the programmed hysteresis.

Setpoints (Option)

The setpoint option converts a BarGraph from an indicator to a differential gap or on/off-style controller. The BarGraph accommodates up to four setpoint locations: Hi/Hi, Hi (alarms when the signal is higher than one of two Hi setpoint values), Lo, and Lo/Lo (alarms when the signal is below one of two low setpoint values).

When any of the alarm values are met, alarm annunciators on the front of the BarGraph light and form “C” relays close. The relay contacts can be used to sound alarms or control the process.

To identify each setpoint location in relationship to the displayed input signal, each LED segment representing the setpoint value will be illuminated when the signal is less than the setpoint value or non-illuminated when the signal is greater than the setpoint value. When the input signal is at a value corresponding to one LED segment above or below the LED segment representing the setpoint value, the setpoint LED segment will flash at a 1 Hertz rate. When the input signal value corresponds to the setpoint LED segment exactly, the LED segment will flash at a 2 Hertz rate.

Temperature Measurement

Weschler BarGraphs may be used to measure temperature using either thermocouples or RTDs (Resistive Thermal Devices). Thermocouples consist of two dissimilar metals joined so that a potential difference is generated that is a measure of temperature. RTDs depend on the fact that the resistance of any metal increases as the temperature increases.

When configured to use RTDs, Weschler BarGraphs provide a fixed current source to drive the RTD. When configured to work with thermocouples, Weschler BarGraphs have internal cold junction compensation and ice point reference. The BarGraph is linearized for the specified thermocouple (J, K, or T) on the order.

Hysteresis

Instrument hysteresis (deadband) can be set at 0.5%, 1%, or 2% of full scale. The hysteresis setting provides a faster or slower response to the trend indicators and setpoints. Other values are possible; please contact the factory for special requirements.

Retransmit (Option)

The BarGraph provides a retransmitted signal (4-20 mA, 0-1 mA, 1-5 VDC, or 0-1 VDC) directly proportional to the zero and full scale of the LED bar indicator. All retransmit signals are factory-set and only need to be verified at installation, even if the input is rescaled.

Peak/Valley (Option)

The Peak/Valley option allows the BarGraph to display the highest (Peak) and lowest (Valley) levels during the reading cycle, as determined by the reset.

Power

All BarGraphs have self-contained power supplies which can be powered by 120/240VAC (50/60/400Hz). DC-powered Bar Graphs can be powered by 5 V ($\pm 5\%$) @ 400 mA, 8 to 50 V, 125 V, or 250 V (+10%). Instrument isolation is accomplished via the power supply transformer for AC sources.

Differential input signal conditioning provides common mode rejection of greater than 80 dB.

3 INSTALLATION

Verification

Remove the BarGraph instrument from its packing container. Check to make sure that the BARGRAPH LABEL (shown below) on the BarGraph and packing container are identical. Verify that the BarGraph number received is what is required for your application. Please verify this number with your purchase order.



Warning: insure that the proper inputs and options were ordered and received. Connecting a BarGraph in the wrong application may cause damage to the instrument!



Meter Label

Mounting

1. Securely mount the BarGraph to the panel using the hardware provided. Panel cutout dimensions for each model are provided in Appendix V.

Torque requirements for BG-241, BG-251, BG-261 and BG-281 are 65-70 inch-pounds maximum.

For BG-252, tighten the screw no more than two turns after the screw point contacts the panel.

2. **BG-252 Only:** Install the meter trim to the front bezel.

Electrical Hookup

Electrical connections should be made after the BarGraph has been mounted. Refer to terminal connection diagrams in Appendix II.

1. Connect the power supply to the appropriately labeled terminals. The proper power supply depends on the model BarGraph ordered. Available power supply options are:

- 120 VAC
- 240 VAC
- 5-12 VDC
- 13-50 VDC
- 110-170 VDC
- 110-250 VDC

2. Connect the signal input leads to the proper terminals. The proper input terminals depend on the model BarGraph ordered. Available input options are:

Input 1 - Voltage or Current, AC or DC

Input 2 - RTD, Magnetic Pickup, J, K, or T Thermocouples

Input 3 - Frequency

Input 4 - 3-phase voltage or current

3. If the retransmit option was ordered, connect the analog retransmit signal output. Output levels of the retransmit option depend on the model BarGraph ordered. Available output level options are:

- 4-20 mADC
- 0-1 mADC
- 1-5 VDC
- 0-1 VDC

3. If the serial communication option was ordered, connect the communication transmit and receive lines. Output levels of the serial communication option depend on the option ordered. Available input/output options are:

- RS-232
- RS-422
- RS-485

4. If alarm setpoint options were ordered, connect the appropriate lines to the setpoint options. Setpoint connections are clearly labeled for C (common), NO (normally open) and NC (normally closed). These connections are made to Form C relays within the BarGraph.

4 SETUP

Normal Display Operation

The bar and digital displays provide visual analog indication of the process signal. When the incoming signal is below the bottom end of the bar display, the first LED and the digital display flash at a 1 Hz rate, indicating an underrange condition. When the process signal exceeds the full scale value, the top LED and the digital display flash at a 1 Hz rate, indicating an overrange condition.

The bar and digital display can be inhibited from flashing in the underrange/overrange condition by installing a permanent jumper on JA6. See Appendix IV, Circuit Board Layout Drawings, for the locations of jumpers.

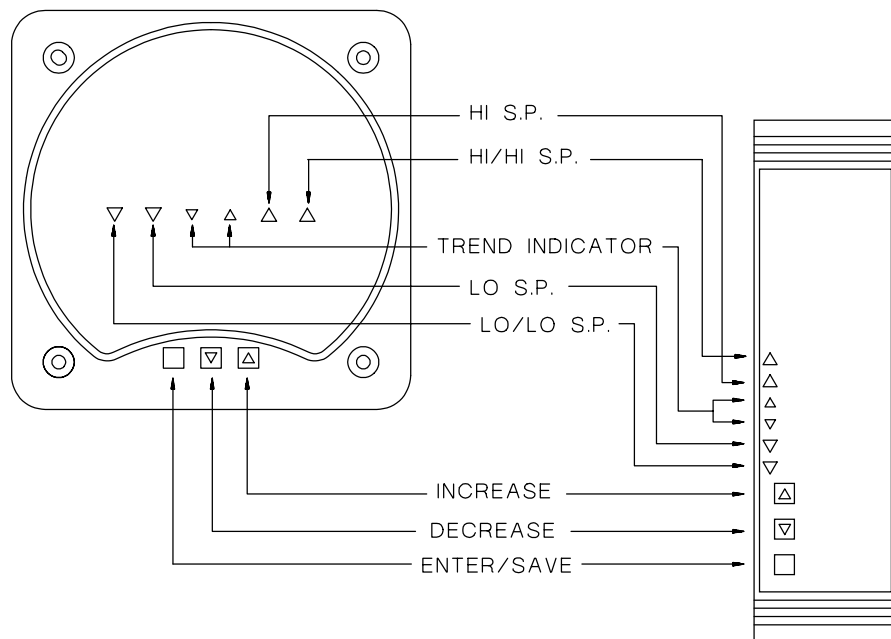

Display Operation During Setup

During setup programming, the bar and digital displays provide information to the user for programming. The digital display is used to show simple 2-number abbreviations and numeric values for each of the setup functions and the bar display is used to provide an analog indication of functions and function values.

Information from the user is input through pushbuttons on the front panel of your BarGraph. To access these pushbuttons on the BG-251, BG-261 and BG-281, the front cover must be removed.

There are three pushbuttons: INCREASE (▲), DECREASE (▼) and ENTER/SAVE (■).

Operator and Supervisor Setup

Setup functions are divided into two separate classes: Operator and Supervisor.

Operator Setup functions are those that may need to be changed on a routine basis for normal operation of the instrument. These functions include only the alarm setpoints. Alarm setpoint programming may be disabled under Supervisor Setup.

Supervisor functions are those that should be setup only once when the instrument is installed and may cause damage to equipment or faulty operation if changed inadvertently. These functions include calibration settings, retransmit ID settings and bar display modes.

Supervisor Setup functions may only be programmed by installing a jumper at JA1.

4.1 OPERATOR SETUP PROGRAMMING

Activating Operator Setup

If Operator Setup was enabled under Supervisor Setup (see Section 4.2 for details), pressing the red ENTER pushbutton and holding it for more than 3 seconds activates Operator Setup without installing a jumper at JA1.

When operator setup is first enabled, the first function available is displayed on the digital display. This is the point at which the user both enters and leaves Operator Setup. While continuing to hold the ENTER (▣) key, press the INCREASE (▲) or DECREASE (▼) keys to cycle through the available alarm settings.

Operator Setup Actions

Operator Setup allows alarm setpoint values to be changed. Note that the number of alarm setpoints available depends on the particular model BarGraph™ ordered.

Operator Setup functions are cycled through using the INCREASE and DECREASE keys while still holding the ENTER/SAVE key. A particular function can be programmed by releasing the ENTER/SAVE key. Pressing the DECREASE key while 04 is displayed will go to 03 and pressing the INCREASE key while 04 is displayed will go to 00.

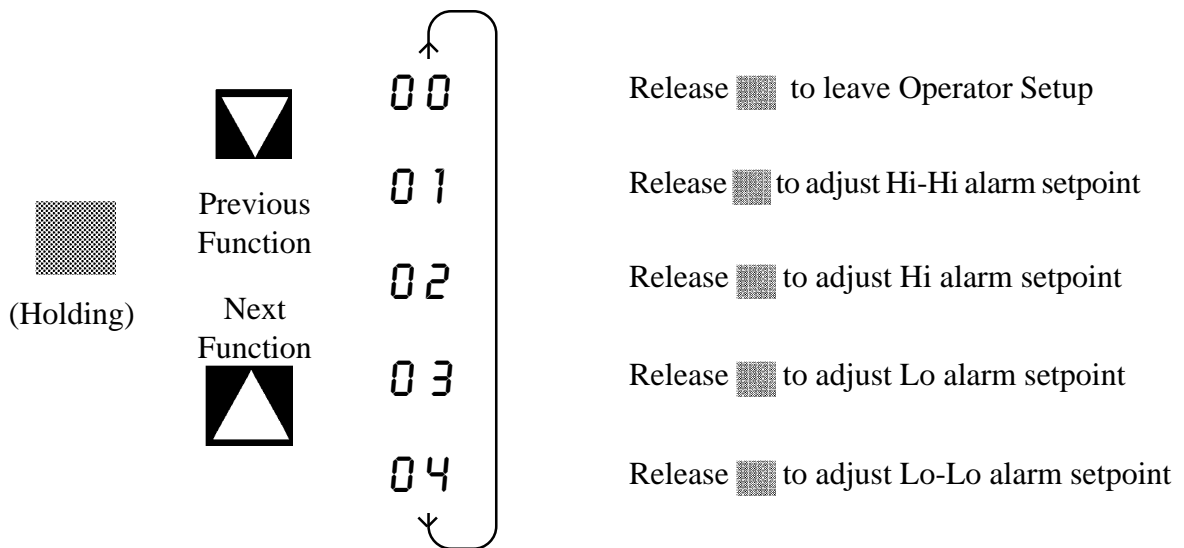

Releasing the ENTER key while any of the above are displayed will display the current setting and allow it to be modified. Setting each of the above functions is described on the following pages.

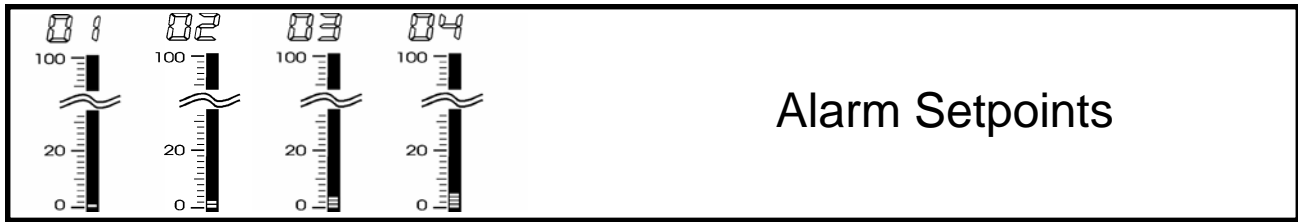

Up to four alarm setpoints are provided, depending on the exact model of BarGraph™ ordered and the options supplied. Each of the available setpoints may be programmed for a specific value under Operator Setup if enabled (see Enable/Disable Operator Setup in Section 4.2).

- 01 - Hi-Hi Setpoint
- 02 - Hi Setpoint
- 03 - Lo Setpoint
- 04 - Lo-Lo Setpoint



Press and *Hold*
ENTER

After 3 seconds, the display will show 01 to indicate that Operator Setup mode has been entered.



Press
INCREASE
DECREASE

Continue to hold ENTER/SAVE and press INCREASE or DECREASE until the desired setpoint code is displayed.



Release
ENTER

Release ENTER/SAVE to display and change the current setpoint value. The bar and digital displays both indicate current setpoint value.



Press
INCREASE
DECREASE

INCREASE and DECREASE keys are used to change the setpoint value. Hold it until the new setpoint value is reached.

The longer the key is held, the faster the display moves to the required location.



Press
ENTER

To save the new setpoint value, press the ENTER key. The display will momentarily show the next setpoint code before displaying its value and allowing it to be changed. In this way, all alarm setpoints may be examined and changed.

NOTE: Do not assume that the new value is saved once you have arrived at the new setpoint value and the BarGraph™ defaults to normal display mode. You must press ENTER to store the new setpoint value and make it effective.

NOTES

If the BarGraph™ is in 01 through 04 and no keys are pressed for 45 seconds, the BarGraph™ reverts to the normal display.

In Operator Setup mode, only the bar and digital displays are affected. All signal processing functions continue to operate at the current setup values. Thus, if you are using the setpoint form "C" relays or retransmit capabilities, they continue to function as if the BarGraph™ was in the normal display mode.

4.1.1 FAILSAFE SETPOINT SETUP PROCEDURE

For Models Ordered with Failsafe Setpoint Option Only

The failsafe setpoint feature takes advantage of the inversion of operation when low alarms are used as high alarms and high alarms are used as low alarms. This may be a bit confusing, but once understood, is completely logical. Note that special software is required for the hysteresis to operate properly with failsafe relays.

High Setpoint

The low alarm energizes (picks up) the relay whenever the signal is below its setpoint value and deenergizes (drops out) the relay whenever the signal is above its setpoint. Thus, if the low alarm setpoint value is set to what would normally be the high setpoint value, when the signal exceeds the setpoint the relay will drop out and when the signal drops below the setpoint value the relay will pick up. Connecting an external device to the relay's normally closed contact will provide an open contact when the signal is below the setpoint and a closed contact when the setpoint is exceeded OR the relay fails. This is the definition of a failsafe high setpoint.

The High-High setpoint value and the Lo setpoint value must be set to the same desired high setpoint value. This ensures that the high setpoint annunciator on the bar display tracks the high failsafe alarm. Connections to the normally closed relay contact of two BG-252 models are made with respect to figure 4.1.1 below. Other BG models are connected in a similar fashion.

Low Setpoint

The high alarm energizes (picks up) the relay whenever the signal is above its setpoint value and deenergizes (drops out) the relay whenever the signal is below its setpoint. Thus, if the high alarm setpoint value is set to what would normally be the low setpoint value, when the signal drops below the setpoint the relay will drop out and when the signal exceeds the setpoint value the relay will pick up. Connecting an external device to the relay's normally closed contact will provide an open contact when the signal is above the setpoint and a closed contact when the signal is below the setpoint OR the relay fails. This is the definition of a failsafe high setpoint.

The LoLo setpoint value and the Hi setpoint value must be set to the same desired high setpoint value. This ensures that the low setpoint annunciator on the bar display tracks the low failsafe alarm. Connections to the normally closed relay contact of two BG-252 models are made with respect to figure 4.1.1 below. Other BG models are connected in a similar fashion.

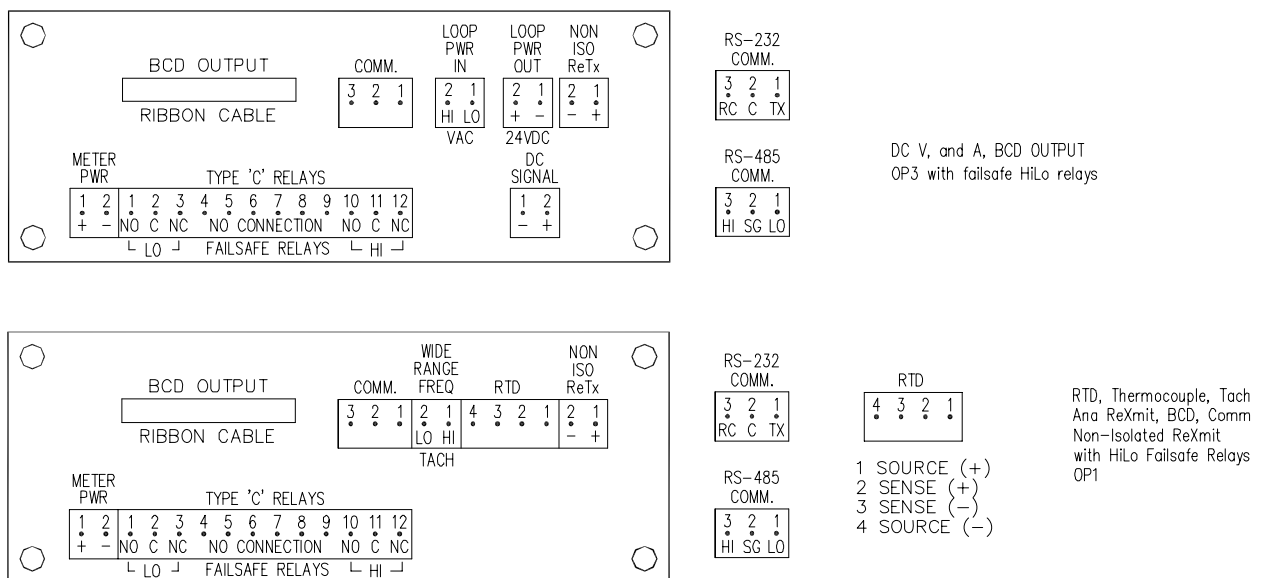

Figure 4.1.1 Connections to BG-252 Failsafe Relays

4.2 SUPERVISOR SETUP PROGRAMMING

Activating Supervisor Setup









Supervisor Setup can only be activated by installing a jumper on JA1. Refer to Appendix IV, Circuit Board Layout Drawings, for the location of JA1.











When Supervisor Setup is first enabled, 00 is displayed on the digital display. This is the point at which the user both enters and leaves Supervisor Setup. No segments on the BarGraph™ display should be illuminated.

Supervisor Setup Functions

Supervisor Setup allows the following functions. Note that the number of alarms available depends on the particular model of BarGraph™ display ordered.

Supervisor Setup functions are cycled through using the INCREASE and DECREASE keys. A particular function can be set by pressing the ENTER key. Pressing the INCREASE key while 14 is displayed will go to 00 and pressing the DECREASE key while 00 is displayed will go to 14.

	to 14	
	↑	
	00	Enter and Exit Setup
Previous	01	 Configure Alarm 1 (if ordered)
Function	02	 Configure Alarm 2 (if ordered)
	03	 Configure Alarm 3 (if ordered)
Next	04	 Configure Alarm 4 (if ordered)
Function	05	 Enable/Disable Peak/Valley (if ordered)
	06	 Configure Hysteresis (if ordered)
	↓	
	Next	
	Page	

	↓		
		07	 Calibrate Zero
		08	 Calibrate Full-scale
		09	 Configure Barform
Previous Function		10	 Enable/disable Operator Setup
		11	 Configure Decimal Point Scaling
		12	 Configure BarGraph™ Zero
Next Function		13	 Configure BarGraph™ Full-scale
		14	 Set Communication ID
	↓		
	to	00	

Codes 1 through 6; 11, 12, 13 and 14 are only displayed if the respective option was ordered. To add these capabilities, contact the factory.

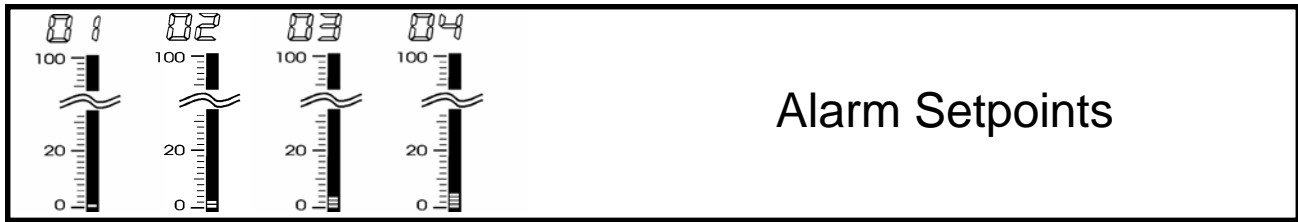

Up to four alarm setpoints are provided, depending on the exact model of BarGraph™ ordered and the options supplied. Each of the available setpoints may be programmed for a specific value under Supervisor Setup.

- 01 - Hi-Hi Setpoint
- 02 - Hi Setpoint
- 03 - Lo Setpoint
- 04 - Lo-Lo Setpoint



Press
INCREASE
DECREASE



Press INCREASE or DECREASE until the desired setpoint code is displayed.



Press
ENTER



Press ENTER to display and change the current setpoint value. The bar and digital displays both indicate current setpoint value.



Press
INCREASE
DECREASE



INCREASE and DECREASE keys can be used to change the setpoint value. Hold it until the new setpoint value is reached.

The longer the key is held, the faster the display moves to the required location.



Press
ENTER



To save the new setpoint value, press the ENTER key. The display will momentarily show the next setpoint code before displaying its value and allowing it to be changed. In this way, all alarm setpoints may be examined and changed.

NOTE: Do not assume that the new value is saved once you have arrived at the new setpoint value and the BarGraph™ defaults to normal display mode. You must press ENTER to store the new setpoint value and make it effective.



Peak/Valley allows the BarGraph™ to display the highest (Peak) and lowest (Valley) level during the reading cycle, as determined by the reset. This function will only be available if the BarGraph™ was ordered with Peak/Valley option.



Press
ENTER



The display will show 0 (disabled) or 1 (enabled) to indicate the current state of Peak/Valley function.



Press
INCREASE
DECREASE



Pressing the INCREASE or DECREASE key will toggle between 0 (disabled) and 1 (enabled).



Press
ENTER



Press ENTER to store the new setting.



Hysteresis may be set to .5, 1.0 or 2.0 % of Full Scale. This function will only be available if the BarGraph™ was ordered with Relay option.



Press
ENTER



The display will show the current hysteresis setting.



Press
INCREASE
DECREASE



Pressing the INCREASE or DECREASE key will increase or decrease the hysteresis setting. Pressing INCREASE while at 2.0 will roll over to .5 Pressing DECREASE while at .5 will roll over to 2.0.



Press
ENTER



Press ENTER to store the new setting.

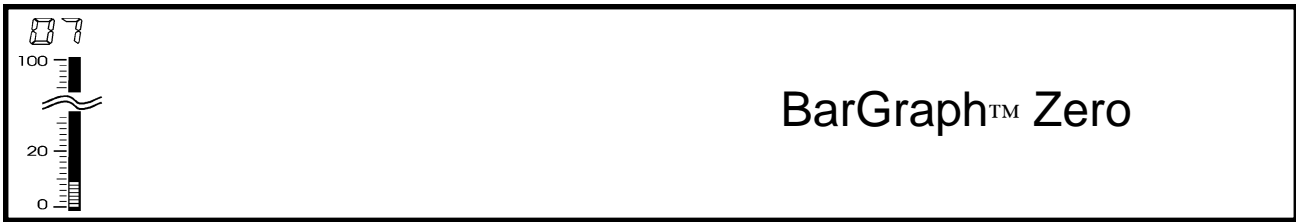

This is a calibration function. The following steps show how to check the current calibration settings. For a description of how to change the calibration, see section 3 for complete calibration procedure.



Press
ENTER



The display will show the current BarGraph™ zero.

If you merely want to examine the settings without changing them, omit the next step. Pressing the INCREASE or DECREASE keys at this point will change the Zero setting!



Press
INCREASE
DECREASE



Pressing the INCREASE or DECREASE keys will change the calibration settings. See section 3 for a complete description of calibration.



Press
ENTER



Press ENTER to advance to the next function (BarGraph™ Full Scale).



This is a calibration function. The following steps show how to check the current calibration settings. For a description of how to change the calibration, see section 3 for complete calibration procedure.



Press
ENTER



The display will show the current BarGraph™ Full Scale display setting.

If you merely want to examine the settings without changing them, omit the next step. Pressing the INCREASE or DECREASE keys at this point will change the Full Scale setting!



Press
INCREASE
DECREASE



Pressing the INCREASE or DECREASE keys will change the calibration settings. See section 3 for a complete description of calibration.



Press
ENTER



Press ENTER to advance to the next function (Set Barform).



This function allows the user to set the display format. The most common display format is bottom zero, ie; starts at the bottom (or left) and increasing up (or to the right). The BarGraph™ zero point can be located or referenced anywhere on or off the scale in this setup.



Press
ENTER



The display will show the current barform. Options for barform and the order they appear in are shown below.



Press
INCREASE
DECREASE



Pressing the INCREASE or DECREASE key will cycle through the barform options shown below.



Previous
Barform



Next
Barform

- 0
- 1
- 2
- 3
- 4
- 5
- 6
- 7

Bottom 0. BarGraph™ reads 0% of Full Scale at the bottom and increasing up to 100% of Full Scale at the top.

Zero point at 25% of bar display. BarGraph™ reads -25% of bar display at the bottom and increases up to +75% at the top.

Zero point at 33% of bar display. BarGraph™ reads -33% of bar display at the bottom and increases up to +66% at the top.

Zero point at 50% of bar display (Center Zero). BarGraph™ reads -50% of Full Scale at the bottom and increases up to +50% at the top. Positive values are displayed as a bar that extends from center of display up; negative values as a bar from center of display down.

Zero point at 100% of bar display. This effectively reverses the bar display, with 100% of Full Scale at the bottom of bar display and 0% of Full Scale at the top.

Bipolar (Wraparound) - For positive values the zero point is at the bottom of display and reads to 100 % of FullScale at the top of display. For negative values the zero point is at the top of display and reads to -100 % of FullScale at the bottom of display.

Variable allows the user to set any arbitrary values for the bottom and top of bar display (see Set Bar Zero and Set Bar Full Scale).

Deviation allows the user to set a bar display center point at any arbitrary value and display + or - variations around that center point. The value set with BarGraph™ Zero function is displayed at the center of bar display, with - Bar Full Scale at the bottom of display and + Bar Full Scale at the top of bar display. Values greater than BarGraph™ Zero are displayed as a bar that extends from center of display up; values less than BarGraph™ Zero as a bar from center of display down. (see Set Bar Zero and Set Bar Full Scale)



Press
ENTER



Press ENTER to store the new barform setting.

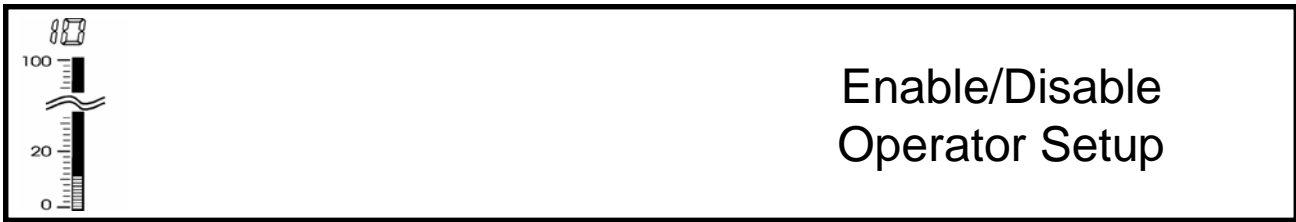

Operator Setup can be enabled or disabled through this function. If Operator Setup is disabled, setpoints for alarms 1 through 4 can no longer be set without jumper JA1.



Press
ENTER



The display will show 0 (disabled) or 1 (enabled) to indicate whether Operator Setup is currently disabled or enabled.



Press
INCREASE
DECREASE



Pressing the INCREASE or DECREASE key will toggle between 0 and 1.



Press
ENTER



Press ENTER to store the new setting.

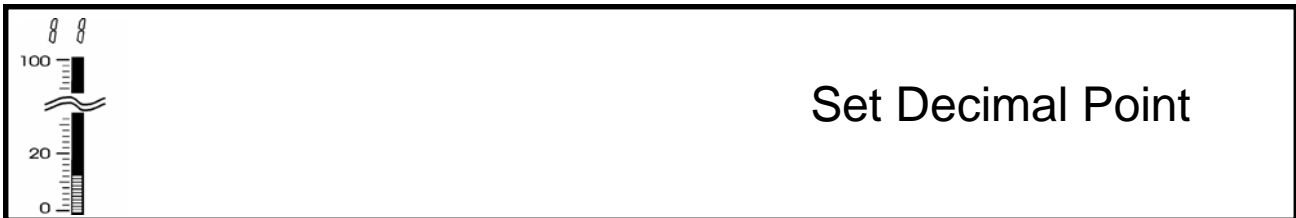

This function is used to set the position of the decimal point on the digital display.



Press
ENTER





The display will show the current display decimal point setting. Options for display decimal settings and the order they appear are shown below.





Press
INCREASE
DECREASE





Pressing the INCREASE or DECREASE key will cycle through the display decimal point setting options shown below.



 Previous Position	0	No decimal point.
	1 .	Decimal point after least significant digit on display.
Next Position 	2 .	Decimal point after 2nd least significant digit on display.
	. 3	Decimal point after 3rd least significant digit on display.
	. 4	Decimal point after 4th least significant digit on display.
	. 5	Decimal point after most significant digit on display.



  Press ENTER to store the new setting.
 Press
 ENTER



The BarGraph™ zero display point may be set to a percentage of Full Scale. This is not a calibration function. It only affects the value the BarGraph™ will display at the lowest end of the bar display. This setting can be used to limit the lowest value that the BarGraph™ will display. This function will not be enabled or displayed unless barform has been set to Deviation or Variable barform (see barform function).

  The display will show the current BarGraph™ zero setting as a percentage of input Full Scale.
 Press
 ENTER

  Pressing the INCREASE or DECREASE key will increase or decrease the zero display point.
 Press
 INCREASE
 DECREASE

  Press ENTER to store the new setting.
 Press
 ENTER



Set Bar Full Scale

The BarGraph™ Full Scale display point may be set to a percentage of Full Scale for measurement. This is not a calibration command. It only affects the BarGraph™ display. This command and the Set Bar Zero function may be used to limit the values shown on the bar display to a specific region of interest. This function will not be enabled or displayed unless barform has been set to Deviation or Variable barform (see Set Barform function).



Press
ENTER



The display will show the current BarGraph™ Full Scale display setting as a percentage of input Full Scale.



Press
INCREASE
DECREASE



Pressing the INCREASE or DECREASE key will increase or decrease the Full Scale display point.



Press
ENTER



Press ENTER to store the new setting.



Set ID (Option)

This function is used to set BarGraph™ communication ID. Each BarGraph™ hooked to the communication lines must have its own unique ID to distinguish it from other units. The ID may be set from 00 to 99. This function will only be available if the BarGraph™ was ordered with Communication option.



Press
ENTER



The display will show the current communication ID.



Press
INCREASE
DECREASE



Pressing the INCREASE or DECREASE key will increase or decrease the communication ID.



Press
ENTER



Press ENTER to store the new setting.

5 CALIBRATION





WARNING: PREVENT DAMAGE TO YOUR BARGRAPH!

The BarGraph was configured at the factory for certain Zero and Full Scale values. These values should not vary significantly or damage will occur to your BarGraph. Identify the Zero and Full Scale values from the INPUT data on the BarGraph label. If you need significant changes to your configuration, the input circuitry might require modification. Consult the factory for assistance.

Calibration Procedure

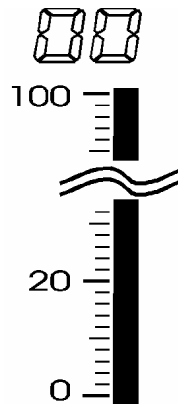
1. Install jumper at JA1 (see circuit board layout drawing in Appendix IV for the location of JA1 in different model BarGraphs). The display changes to:

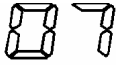

2. To change the BarGraph Zero, press the INCREASE () or DECREASE () pushbuttons until the  display appears and seven segments of the bar display are lit, as shown below:

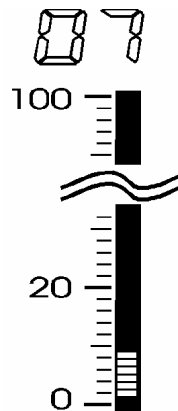

3. Press the red ENTER pushbutton. The display will change to show 000 on the digital display and the bar display will show one segment lit.
4. Check your BarGraph's zero value. Enter the desired zero input value into the BarGraph signal input terminals. Use a calibrated lab-standard.
5. Press INCREASE (▲) or DECREASE (▼) to load the new Zero value into the meter. This tells the unit that you are changing the Zero value, not simply scrolling through setup.

CAUTION: If this step is not performed, the new calibration point will not be saved.

7. Make sure the desired bar segment and digital display value are correct. Press the red ENTER push button and hold it. The desired Zero value is stored in memory and the displays change from the Zero value to 00 on the digital display with 8 bar segments lit, indicating that the BarGraph is ready to calibrate the full-scale value next:

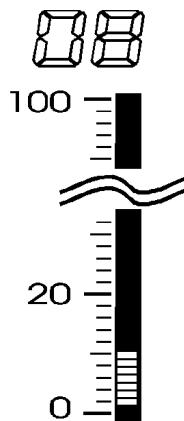

7. When ENTER is released, the displays change to allow setting BarGraph Full Scale:

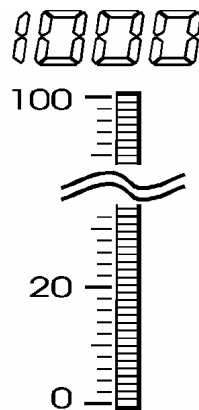

8. The display will change to show the previously stored Full Scale value.
9. Enter the desired Full Scale input value into the BarGraph signal input terminals. Use a calibrated lab-standard.
10. Press INCREASE (▲) or DECREASE (▼) to load the new Full Scale value into the meter. This tells the unit that you are changing the Full Scale value, not simply scrolling through setup.

CAUTION: If this step is not performed, the new calibration point will not be saved.

11. Make sure the desired bar segment and digital display value are correct. Press and hold the red ENTER pushbutton. The desired Full Scale value is stored in memory and the displays change from the Full Scale value to the next setup mode:

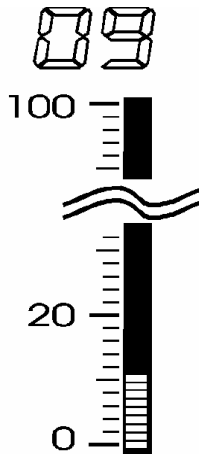

12. While continuing to hold the ENTER pushbutton, use INCREASE (▲) to scroll through the setup modes until you return to 00.
13. Release all pushbuttons and remove the jumper at JA1.
14. Re-check your BarGraph's Zero and Full Scale values with the lab-standard input signal source and verify that you have accomplished the desired results.

6 TEMPERATURE MEASUREMENT

All Weschler BarGraphs shipped with thermocouple inputs are linearized at the factory prior to shipment. Please check the purchase order and the label on the side of the BarGraph to verify the proper thermocouple connection.

A one-hour warm-up period is required to insure accuracy.

Connect the specific thermocouple wire to the compensated miniature connector provided. The following types of thermocouples are supported and the miniature connectors are color-coded as shown below:

- **J** Black
- **K** Yellow
- **T** Blue

7 RETRANSMIT OPTION

All retransmit signals are set at the factory prior to shipment and only need to be verified at installation. If the retransmitted signal needs to be calibrated, see Section 7.1 or 7.2 for retransmit calibration procedure.

Retransmit Output Options

Order Letter	Output Level	Isolated	NON Isolated	Notes
A	4-20 mADC		√	250 Ω load
B	0-1 mADC		√	5 KΩ load
C	1-5 VDC		√	
D	0-1 VDC		√	
F	4-20 mADC	√		
G	0-1 mADC	√		
H	10-50 mADC	√		

Note that Options A and B above have a load resistance specified. If the external instrument resistance varies from these values, external parallel or series resistors may need to be added at the retransmit connector. Variance from the stated resistance causes proportional error in the current delivered.

7.1 RETRANSMIT CALIBRATION

Use this procedure to recalibrate the retransmit option for option letters A, B, C, and D.

1. Remove the BarGraph from its case by unscrewing the front bezel screws and rear case screws.



Warning: Disconnect power before removing BarGraph from case.

2. Refer to Appendix IV, Circuit Board Layout Drawings, to locate the potentiometer for your particular model BarGraph.

Two potentiometers are used to calibrate the retransmit signal: VR1 and VR2. VR1 is used to adjust retransmit full scale output. VR2 is used to adjust retransmit zero output.

3. Apply the proper power source to the BarGraph.
4. Check retransmit zero value. Apply the desired zero input value into the BarGraph signal input terminals, **using a calibrated lab-standard.**
5. Adjust VR2 for the proper retransmit zero output value.
6. Check retransmit full scale value. Apply the desired full scale input value into the BarGraph signal input terminals. **Use a calibrated lab-standard.**
7. Adjust VR1 for the proper retransmit full scale output value.
8. Repeat Steps 4 through 7. Some interaction between the two potentiometer adjustments may occur. Repeat this step until the desired values are reached.
9. Install the rear case and front bezel screws for most circular models or backplate screws for most edgewise models. If you have any trouble or need assistance, please contact the factory.

7.2 ISOLATED RETRANSMIT CALIBRATION

Use this procedure to recalibrate the retransmit option for option letters F, G, and H.

1. Remove the BarGraph from its case by unscrewing the front bezel screws and rear case screws.



Warning: Disconnect power before removing BarGraph from case.

2. Refer to Appendix IV, Circuit Board Layout Drawings, to locate the potentiometers for your particular model BarGraph. For isolated retransmit options, use the Option 4 PC Board Drawing.

Two potentiometers are used to calibrate the retransmit signal: VR1 and VR2. VR1 is used to adjust retransmit full scale output. VR2 is used to adjust retransmit zero output.

3. Connect the proper power source to the BarGraph power connector (P1 of the CPU Printed Circuit Board).



Warning: Do not apply power at this time. Do not place anything in the enclosure when the cover is off.

4. Connect a calibrated source to the input connector (P3 of the CPU Printed Circuit Board). **Insure that the polarity of the input connection is correct.**
5. Connect the appropriate test instrument to the retransmit connector (P6 on the Option 4 Printed Circuit Board). **Make sure the connection polarity is correct.**
6. Apply power to the BarGraph.
7. Check retransmit zero value. Apply the desired zero input value into the BarGraph signal input terminals.

To identify the calibrated zero input, check the BarGraph label for the term "ES=". The first number is the zero input.

8. Adjust VR2 on the Option 4 PCB for the proper retransmit zero output value.
9. Check retransmit full scale value. Apply the desired zero input value into the BarGraph signal input terminals.

To identify the calibrated full scale input, check the BarGraph label for the term "ES=". The second number is the full scale input.

10. Adjust VR1 on the Option 4 PCB for the proper retransmit full scale output value.
11. Repeat Steps 7 through 10. Some interaction between the two potentiometer adjustments may occur. Repeat this step until the desired values are reached.
12. When calibration has been verified, remove power, input and the test instrument from the rear connections.
13. Install the rear case and front bezel screws for most circular models or backplate screws for most edgewise models. If you have any trouble or need assistance, please contact the factory.

8 PEAK/VALLEY OPTION

Valley Display

To display the Valley, press the DECREASE (▼) pushbutton. While pressing the pushbutton, the bar and digital display show the present lowest Valley reading.

The BarGraph continues to operate normally and display correct readings for Trend and Setpoints by illuminating the respective LED annunciator(s).

Valley Capture Cycle

When power is first applied to the BarGraph, the optional digital display shows the software version for three seconds. During this time, no Valley readings are taken. When the BarGraph displays its first reading, the Valley option starts comparing for the lowest input. It continues to survey the input for the lowest value until the reset signal is sent to the microprocessor. The normal cycle is from reset to reset.

Valley Reset

To reset the Valley option, press the DECREASE (▼) pushbutton and simultaneously press the red ENTER/SAVE (■) pushbutton.

Peak Display

To display the Peak, press the INCREASE (▲) pushbutton. While pressing the pushbutton, the bar and digital displays show the present highest Peak reading.

The BarGraph continues to operate normally and display correct readings for Trend and Setpoints by illuminating the respective LED annunciator(s).

Peak Capture Cycle

When power is initially applied to the BarGraph, the digital display (optional) reads the software version for about 3 seconds. During this time, no Peak reading is taken. When the BarGraph displays its first reading, the Peak option starts comparing for the highest input. The BarGraph continues to survey the input for the highest value. This continues until the reset signal is sent to the microprocessor. The normal cycle is from reset to reset.

Peak Reset

To reset the Peak option, press the INCREASE (▲) pushbutton and simultaneously press the red ENTER/SAVE (■) pushbutton.

9 REPLACEMENT PARTS

Quantity	Description	Part Number
3	Pushbutton Switches	510-02001-00
1	Red Pushbutton Cap	510-02002-00
2	Arrow Pushbutton Caps	510-02003-00
1	Fuse (1/4 amp)	430-01001-00
1	M.O.V. (130 V-10A)	430-01002-00
1	Shorting Bar (JA1 Jumper)	210-01007-00
2	2-Pin Male Phoenix Connectors	210-01008-00
1	12-Pin Male Phoenix Connector	210-01010-00
1	3-Pin Male Phoenix Connector	210-53017-00
1	3-Pin Male Phoenix Connector (BG-252 Option Board)	210-53017-00
1	BG-252 Case	140-50001-00
1	BG-241 Front Cover	140-40001-00
1	BG-241 Mounting Hardware	100-49001-00
1	BG-252 Mounting Hardware	100-59001-00
1	BG-252 Trim Strips	282-59001-00
1	BarGraph Protocol Label	900-10002-00

10 WARRANTY

All BarGraph products from Weschler Instruments are warranted against defects in material and workmanship for a period of two years from date of delivery. Weschler Instruments, at its option, will repair or replace all defective instruments returned to it during the warranty period without charge, provided there is no evidence that the equipment has been mishandled or abused. Any repairs or modifications not performed by an authorized factory representative are not warranted by Weschler Instruments. Field service is only available on a contract basis.

Customers must contact Weschler Instruments for RMA number via fax or phone BEFORE returning instruments.

Warranty claims shall be made to Weschler Instruments, 16900 Foltz Parkway, Cleveland, Ohio 44136. Phone: (216) 238-2550; Fax: (216) 238-0660. A Return Material Authorization (RMA) number must be obtained before returning material.

All products returned to Weschler must be insured by sender and must be carefully packaged such as to prevent breakage from shock and rough handling. All applicable shipping charges, insurance, duties and taxes must be prepaid by sender.

Appendix I - BARGRAPH RETROFIT GUIDE

Existing Meter	Weschler Replacement
GE/Yokogawa 180 Sigma/International Instruments 1151 Weschler/Westinghouse V-252/H-252 Crompton 6" A&M Weston 6" Dixson BB101 (All Models) Triplert UB100	BG-252 6" Edgewise Vertical or BH-252 6" Edgewise Horizontal
Weschler/Westinghouse K-231/241 GE Yokogawa AB/DB40 Dixson BEW51/BW051P	BG-241 4 ¹ / ₂ " Square
Hayes-Republic 3600/V5A	BV-5A
Sigma/International Instruments 9262/9263 Dixson BJ101	PC-101/202 72 mm X 144 mm
Bailey Draft Gauges	BD-101 or PG-101/202
Ashcroft 6" gauge Ashcroft 8" gauge	BG-251 6" Circular BG-281 8" Circular
Weschler/Westinghouse K-261 GE/Yokogawa AB/DB16	BG-261 8 ¹ / ₂ " Square
Weston 1316	BW-1316
Hayes Republic 216 Dixon K051	BD-101

Appendix II - Terminal Connections

BG-252, BH-252, BD-101, PC-101, PH-101, PG-101 and PG-202

(PG-202 is a dual BarGraph with two identical stacked terminal layouts)

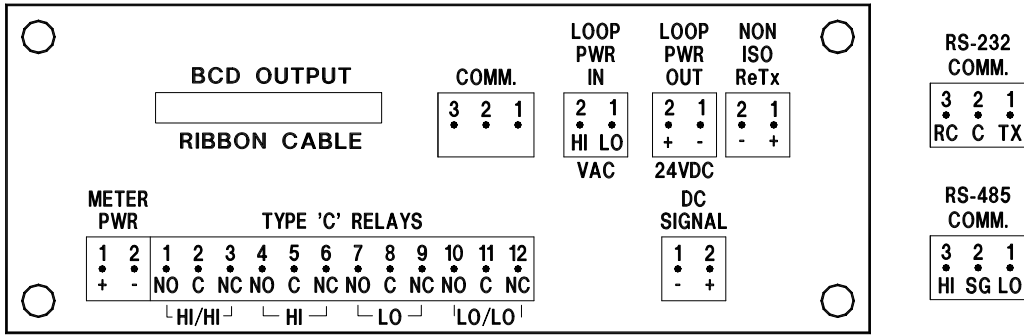

DC Volt, Millivolt, Amp and Milliamp Signal Inputs (OP3)

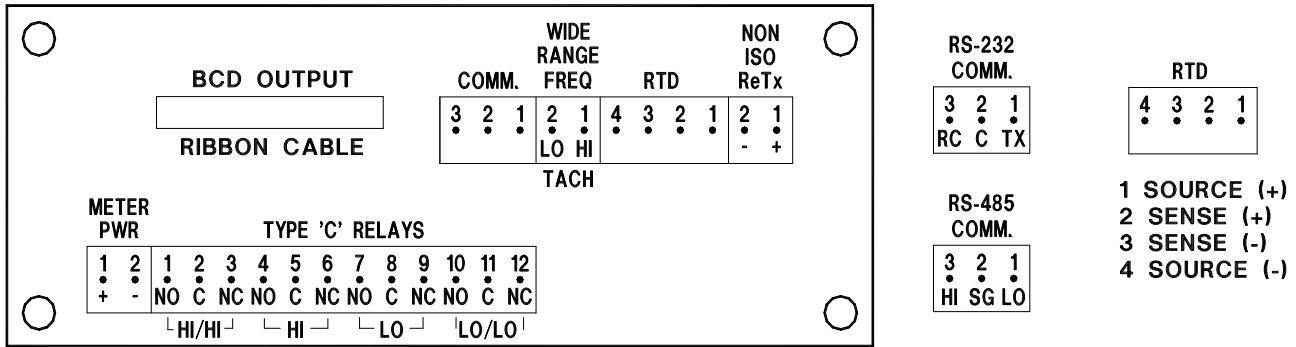

Wide Range Frequency, Tachometer and 3 or 4 Wire RTD Signal Inputs (OP1)

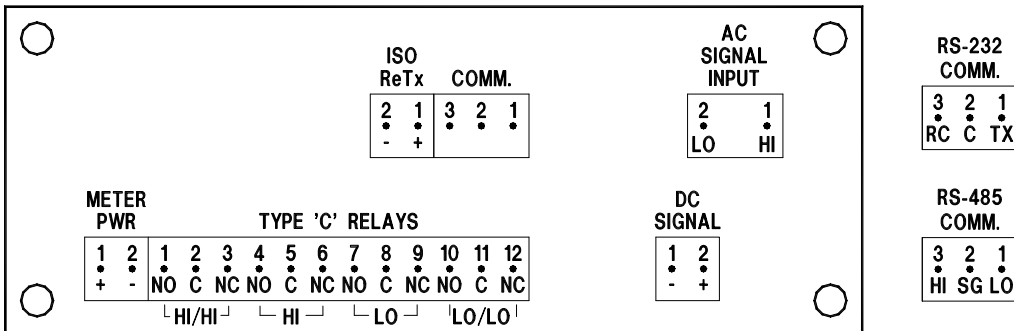

Ac Volt, Millivolt, Amp, Milliamp and Line Frequency Signal Inputs (OP6)

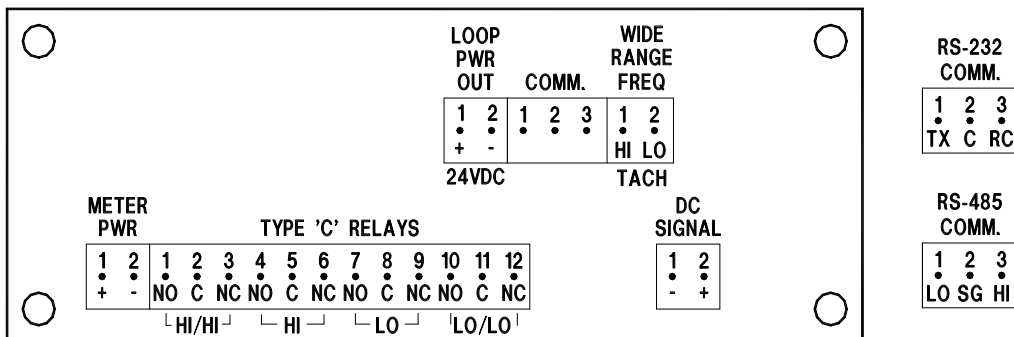

Wide Range Frequency, Tachometer or DC Volt, Millivolt, Amp and Milliamp Signal Inputs (OP4)

BG-241, BG-251, BG-261 and BG-281

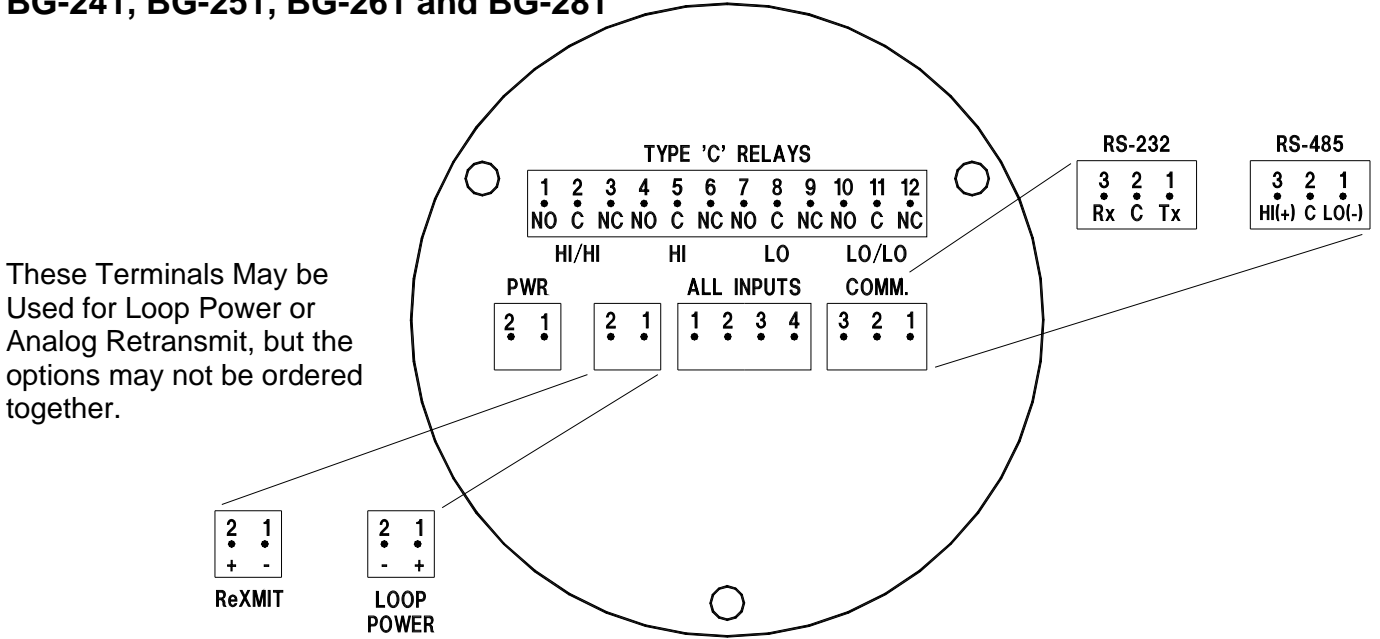

Signal, Input and Output Terminal Assignments

Signal, Input or Output Type	Terminal Number	Assignment	Signal, Input or Output Type	Terminal Number	Assignment
Power	1	HI (+)	Communications (RS-232)	1	Transmit
	2	LO (-)		2	Signal Ground
				3	Receive
Voltage / Current	1	HI (+)	Communications (RS-485)	1	LO(-)
	2	LO (-)		2	Signal Ground
				3	HI(+)
RTD*	1	Source (+)	Relay Contacts	1	HI/HI Normally Open
	2	Sense (+)		2	HI/HI Common
	3	Sense (-)		3	HI/HI Normally Closed
	4	source (-)		4	HI Normally Open
Reluctance Pickup (Tachometer) and Wide Range Frequency	1	HI (+)	5	HI Common	
	2	LO (-)	6	HI Normally Closed	
	3	No Connection	7	LO Normally Open	
Thermocouple	Flying Lead	See Flying Lead Connector	8	LO Common	
			9	LO Normally Closed	
			10	LO/LO Normally Open	
Loop Power	1	HI (+) 24 VDC	11	LO/LO Common	
	2	LO (-)	12	LO/LO Normally Closed	
Analog Retransmit	1	LO (-)			
	2	HI (+)			

* Connect RTD's as shown below:

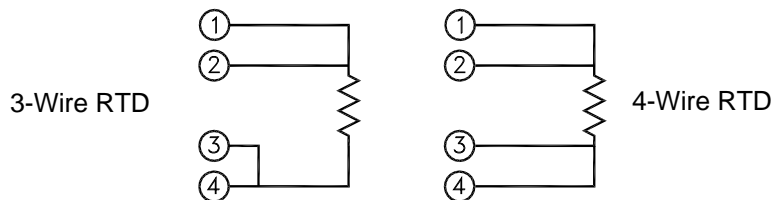

Barrier Terminal Strip Option for BarGraphTypes BG-241, BG-251, BG-261 & BG-281

DC Volt, Millivolt, Amp and Milliamp Signals

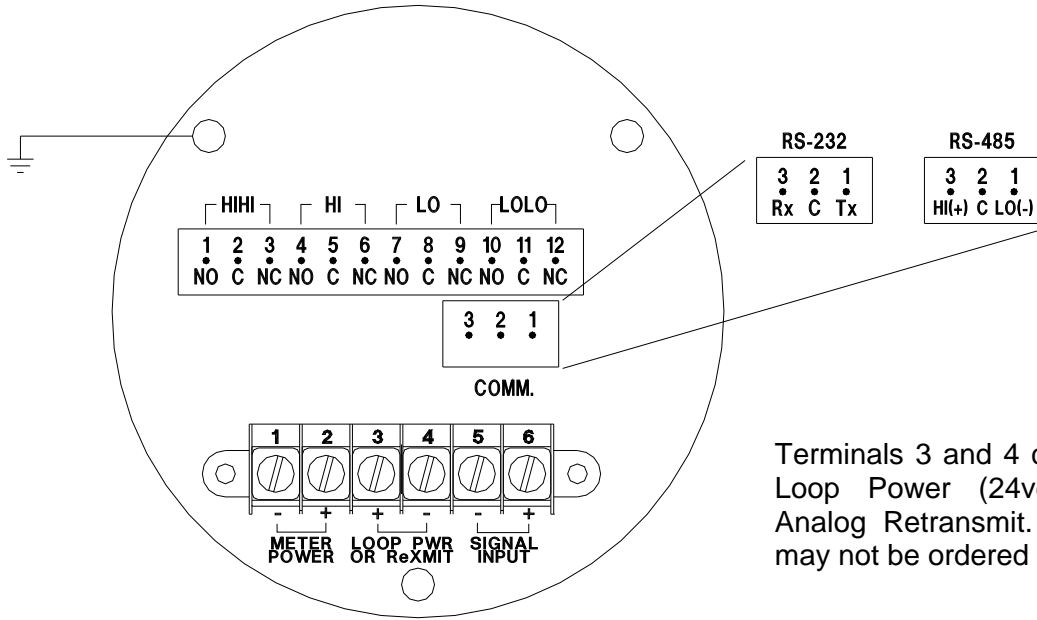

Terminals 3 and 4 can be used for Loop Power (24vdc supply) or Analog Retransmit. These options may not be ordered together.

AC Volt, Millivolt, Amp & Milliamp Signals

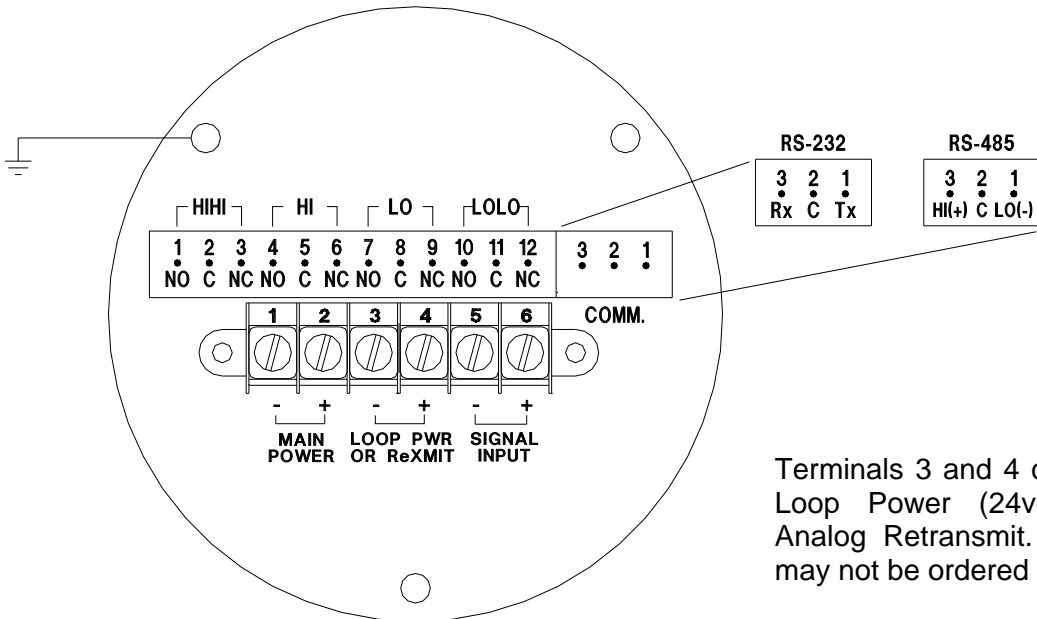

Terminals 3 and 4 can be used for Loop Power (24vdc supply) or Analog Retransmit. These options may not be ordered together.

AC Line Frequency & Synchroscope Signals

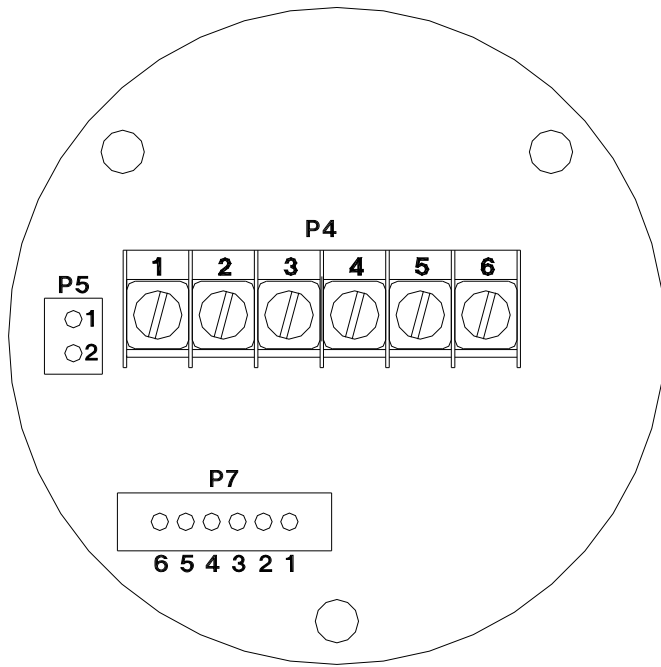

Line Frequency Meter

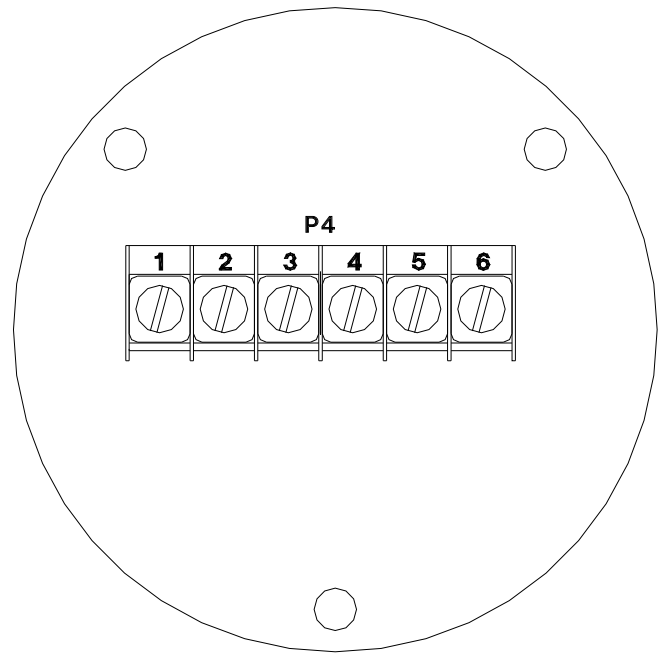

Synchroscope

Terminal Number	Assignment
P4-1	Power Hi (+)
P4-2	Power Lo (-)
P4-3	Signal Lo
P4-4	Signal Hi
P4-5	No Connection
P4-6	No Connection
P5-1	Analog Retransmit Lo (-)
P5-2	Analog Retransmit Hi (+)
P7-1	HI Alarm Relay Normally Open
P7-2	HI Alarm Relay Common
P7-3	HI Alarm Relay Normally Closed
P7-4	LO Alarm Relay Normally Open
P7-5	LO Alarm Relay Common
P7-6	LO Alarm Relay Normally Closed

Terminal Number	Assignment
P4-1	Power Hi (+)
P4-2	Power Lo (-)
P4-3	Running Machine Lo
P4-4	Running Machine Hi
P4-5	Incoming Machine Lo
P4-6	Incoming Machine Hi

Wattmeter Wiring

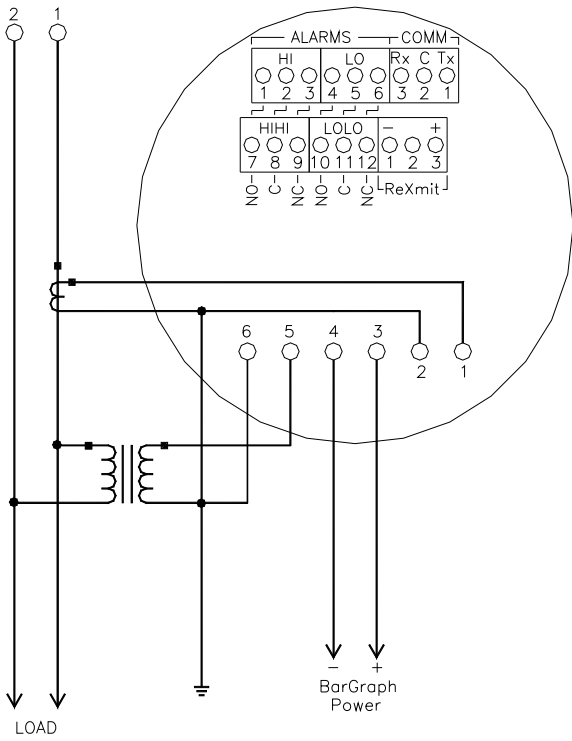

Single Phase

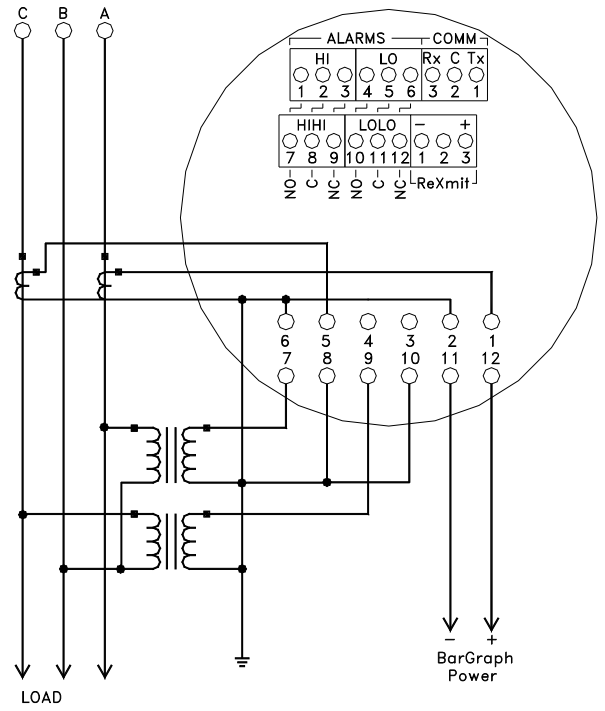

3 Phase 3 Wire

For all Watteters; when using RS-485 communications, the number 1 terminal is LO(-), the number 2 terminal is signal ground and the number 3 terminal is HI(+).

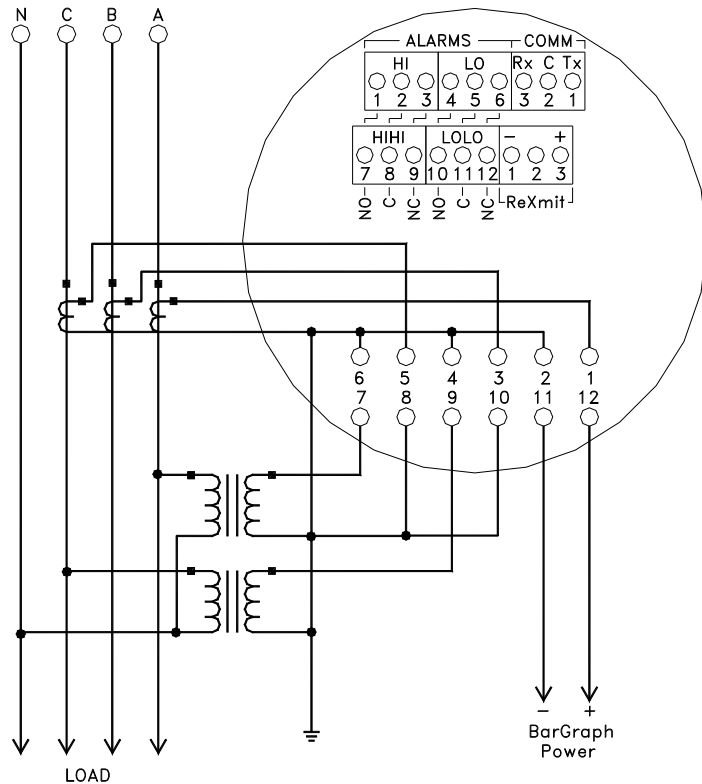

3 Phase 4 Wire

Varmeter Wiring

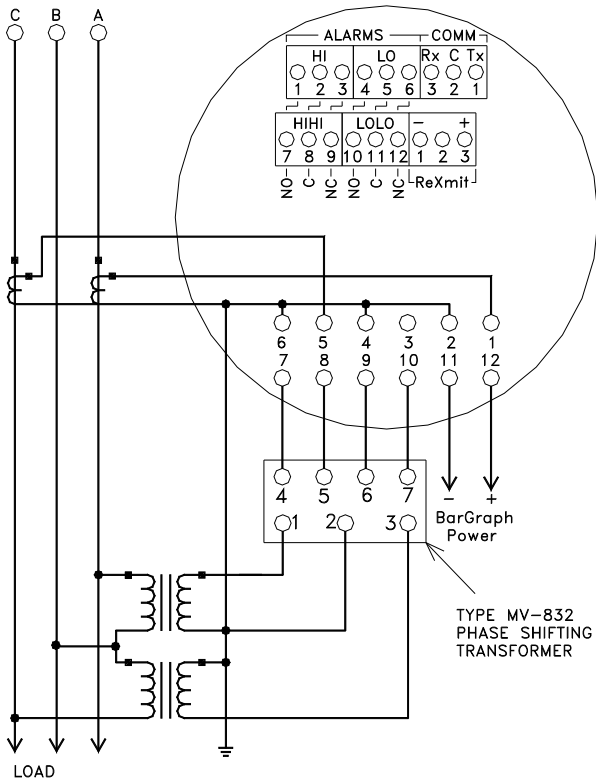

3 Phase 3 Wire with Phase Shifting Transformer

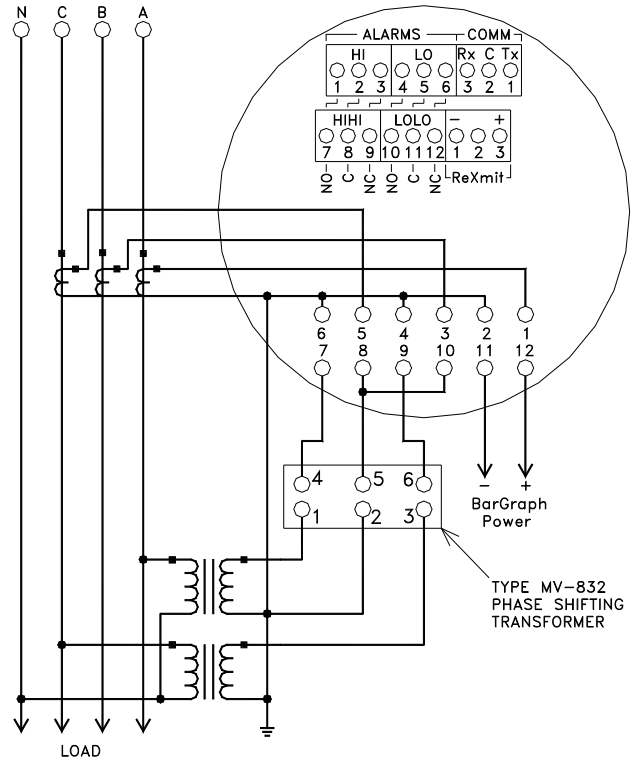

3 Phase 4 Wire with Phase Shifting Transformer

For all Varmeters; when using RS-485 communications, the number 1 terminal is LO(-), the number 2 terminal is signal ground and the number 3 terminal is HI(+).

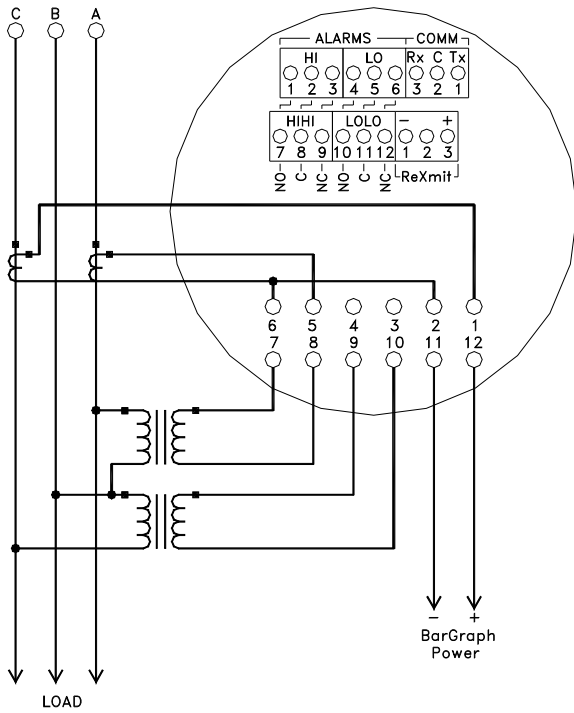

3 Phase 3 Wire Cross-Phase Connected

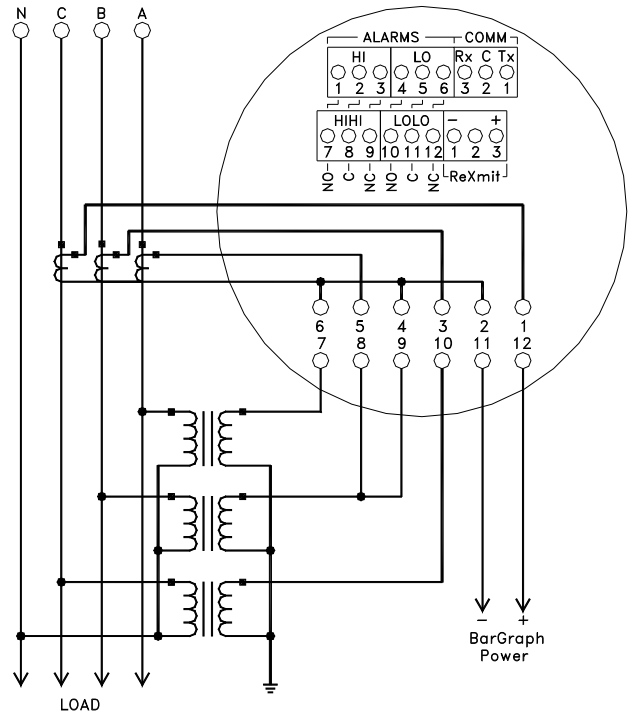

3 Phase 4 Wire Cross-Phase Connected

Power Factor Meter Wiring

Bar grows counterclockwise and numeric display indicates a negative sign for lagging power factor. Bar grows clockwise and numeric display indicates positive for leading power factor.

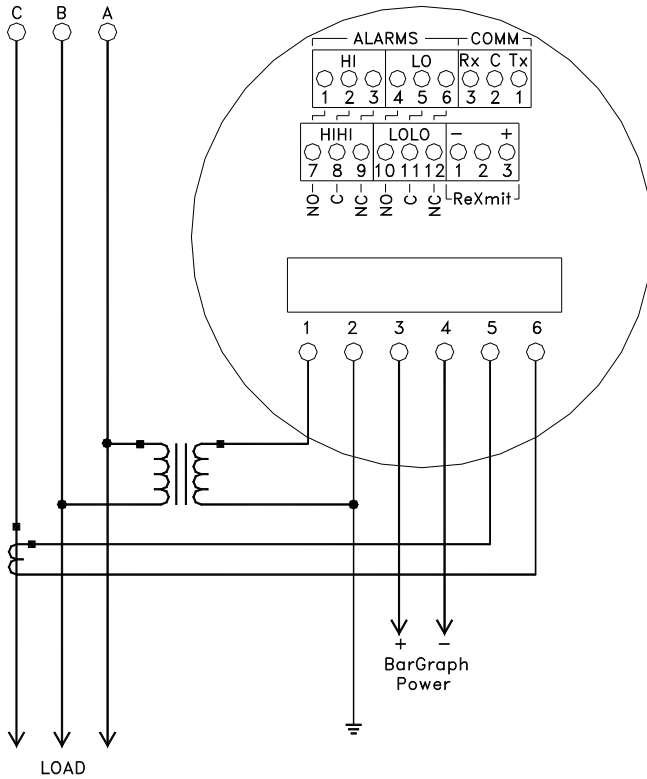

3 Phase 3 Wire

For all Power Factor Meters; when using RS-485 Communications, the number 1 terminal is LO(-), the number 2 terminal is signal ground and the number 3 terminal is HI(+).

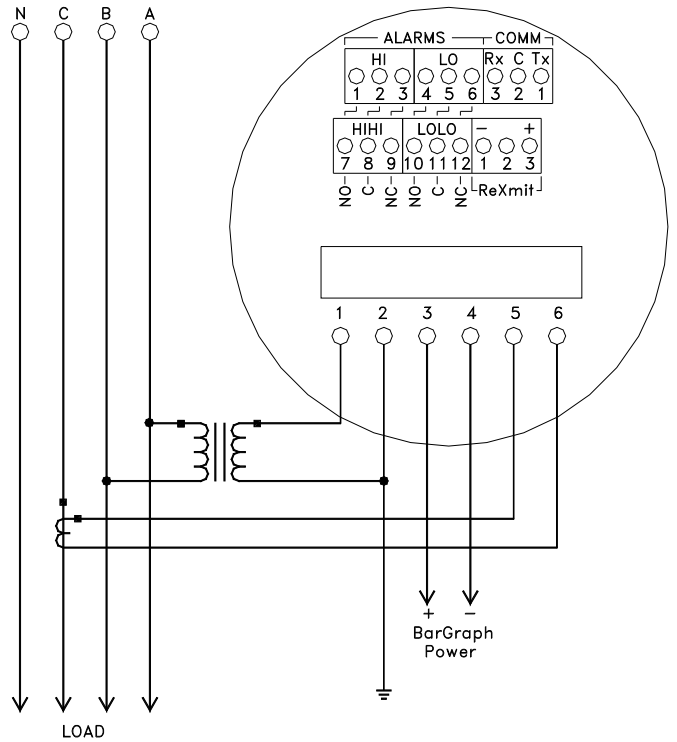

3 Phase 4 Wire

RS-485 Communications Connections

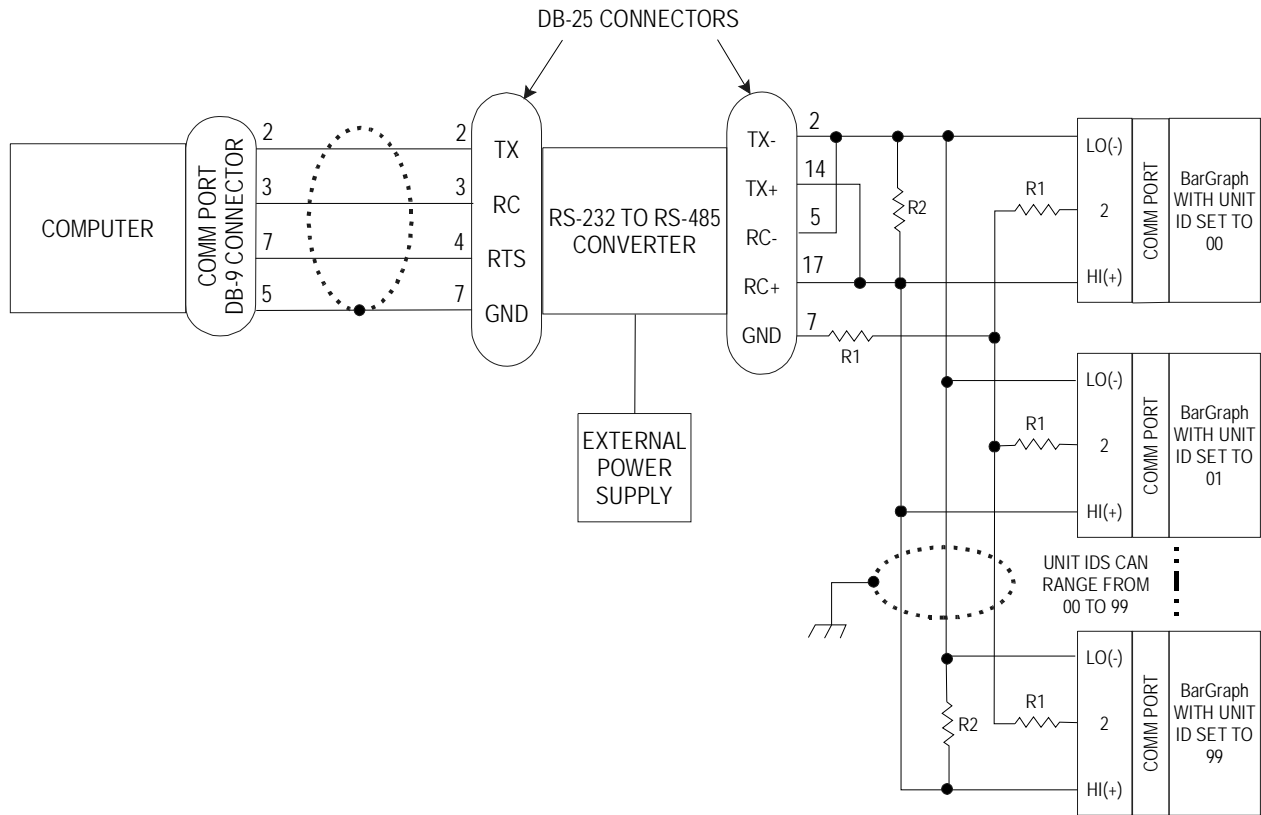

1. Add 120 ohm termination resistors (R2) at the output of the converter and to the terminals of the last BarGraph on the branch circuit.
2. Add 100 ohm resistors (R1) between the signal ground of the converter and to terminal 2 of each BarGraph.
3. Up to 32 BarGraphs may be connected to a common RS-485 branch circuit. Each BarGraph must have its own unique unit ID, selected from a range of 0-99 hex (0-153 decimal). The BarGraph display shows unit ID's as decimal numbers, but the communications protocol transmits unit ID's as hex numbers. Thus the displayed unit ID must be converted to hex in order for the host computer to be able to address it.
4. See the connections diagrams on the previous pages for positions of the HI and LO terminals.
5. The computer, converter, cabling and resistors shown are user supplied. The converter shown is a B&B Electronics model 485HSPR; other converters may not have terminal numbering as shown, but the terminal function must be the same.
6. See individual connection diagrams on previous pages for terminal HI(+) and LO(-) positions.

Appendix III - SPECIFICATIONS

Bar Display

101 Segment LED, 1% full scale

Linear Displays:

BG-252, PC-101, PC-202: 4.0"

BD-101: 10.0"

Circular Displays:

BG-241: 285°

BG-261, BG-281: 270°

BG-251: 270°/345°

51 Segment LED, 2% full scale

Linear Display:

PG-101, PG-202: 5.1"

Digital Display

3-¹/₂ or 4-¹/₂ Digit

Linearity: 1 count

Resolution:

3-¹/₂ Digit: 0.1% full scale

4-¹/₂ Digit: 0.01% full scale

Height:

BG-241, BD-101: 0.4"

BG-252, PC-101, PC-202: 0.3"

BG-261, BG-281: 0.8"

BG-251, PG-101, PG-202: 0.56"

Response Time

DC: < 600 msec full scale

AC: < 800 msec full scale

Temperature

Operation: 0° to 50°C @ 95% RH

Storage: -40° to 85°C

Input Isolation

AC: Transformer Isolated

DC: Differential

Impedance

100 KΩ DC @ > 4 V Input

30KΩ @ 120VAC P.T.

0.1Ω @ 5 AAC C.T.

Overload

200%, DC Current, not to exceed 10 ADC

200%, not to exceed 250 VDC

125%, rated AC Current and Voltage, 5A, 120V

Hysteresis

0.5, 1.0, 2.0% of full scale, selectable

(other values are available)

Retransmit Signals

4-20 mA 0-1 mA

1-5 VDC 24 VDC (excitation power)

Communication

RS-232, RS-422, RS-485

Power

120/240 VAC 50/60/400 Hz (6.0 VA) ±15%

12, 24, 28, 48, 125 or 250 VDC; ±10%

Input Sensitivities

DC

Currents: 50 μ ADC - 5 ADC
DC Voltage: 50 mV - 250 VDC
Accuracy: $\pm 0.04\%$ of full scale
Impedance: 100 K Ω @ > 4VDC
250 Ω @ 4-20 mADC
100 Ω @ 10-50 mADC

TRMS

Current: 1 mA - 5 AAC
Voltage: 50 mV - 250 VAC
Accuracy: $\pm 0.1\%$ of full scale

Temperature - Thermocouple

Thermocouple	$^{\circ}$ C	$^{\circ}$ F
Type J	- 210 to 795	- 350 to 1500
Type K	- 270 to 851	- 450 to 1600
Type T	- 270 to 400	- 450 to 750
Type E	- 270 to 702	- 450 to 1300

Accuracy: 0.1% of full scale
Linearity: 50 point, 0.1%

Temperature - RTD 100 Ω Platinum

Temperature Range: - 260 $^{\circ}$ C (- 436 $^{\circ}$ F); 700 $^{\circ}$ C (- 1292 $^{\circ}$ F)
Accuracy: 0.2% of full scale

Temperature - RTD 10 Ω Copper

Temperature Range: - 100 $^{\circ}$ C (- 148 $^{\circ}$ F); 260 $^{\circ}$ C (500 $^{\circ}$ F)
Accuracy: 0.2% of full scale

Frequency: 50 Hz to 25 kHz

Accuracy: 0.1% of full scale

Line Frequency: 45 to 65 Hz

Accuracy: 0.01% of full scale

Warranty: Two Years. See Section 11 for more information.

Appendix IV - Circuit Board Layout Drawings

CPU Module: BG & BH-252, BD-101, BW-1316, BI-1251, BV5A, PC & PH-101 & 102, PC-202, PG-101 & 202, ML-202, BF-6400 & 6402

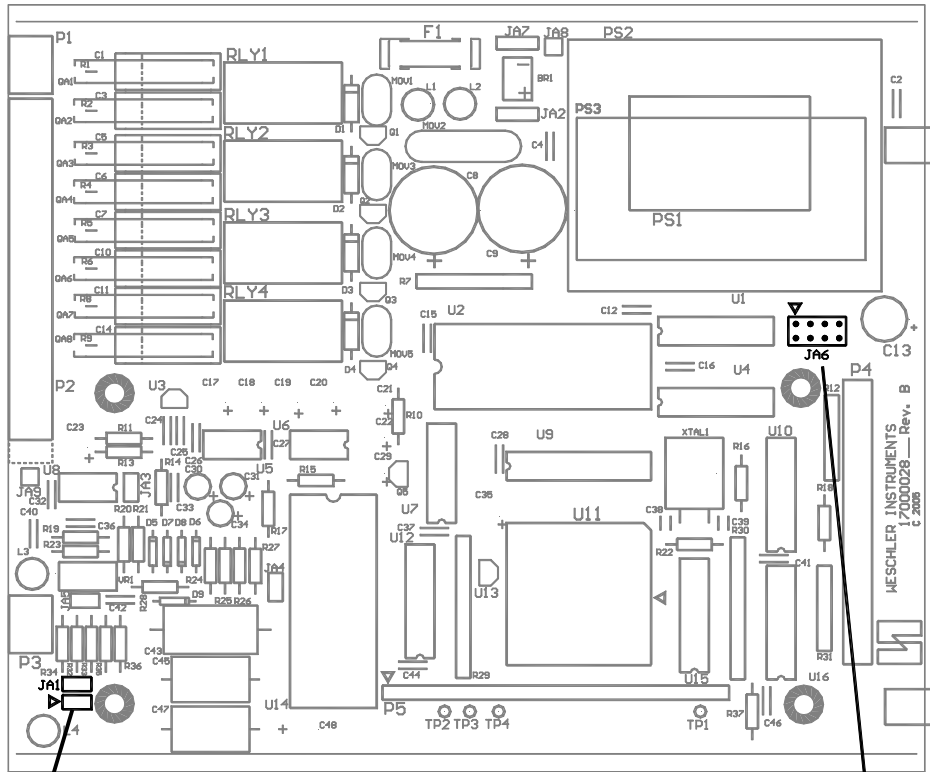

JA-1: Install a Jumper to Enter Supervisory Set-up

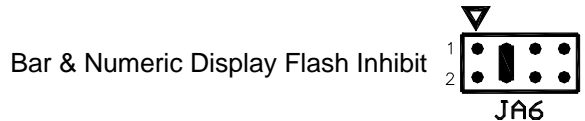
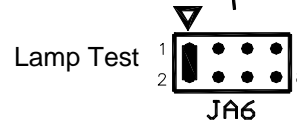

Circuit Board Layout and Jumper Positions

The JA-1 connector is a 90° pin header that is accessible through a slot in the rear panel. Positions 1 and 2 are electrically paralleled and are used alternately for different enclosure sizes. The jumper is installed when it is desired to enable entry into the supervisory set-up mode of operation.

The JA-6 connector is used to select display options. The connector can only be accessed by removing the CPU from the enclosure. Install a jumper across one of the three positions shown above to enable the indicated feature. Pin positions 7 and 8 are not used.

BG-261, BG-281

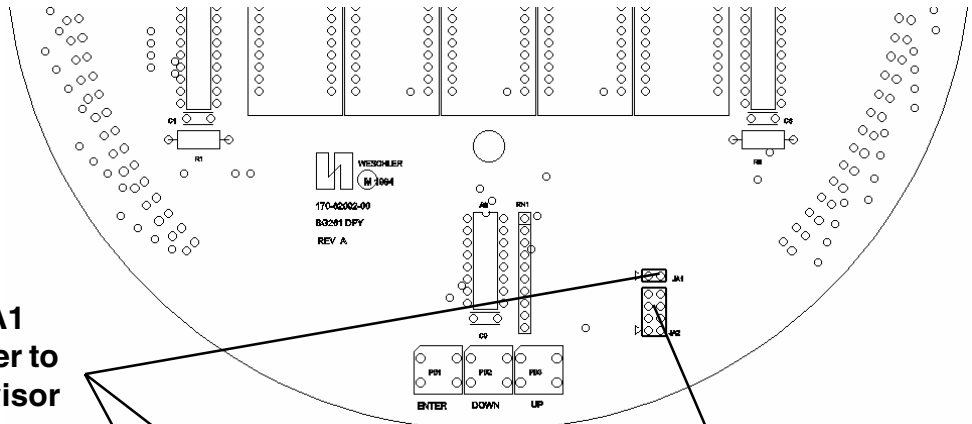

**Jumper JA1
(install jumper to
enter Supervisor
Setup)**

BG-251

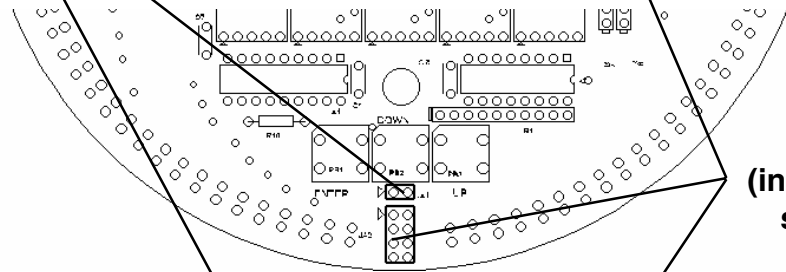

**Jumper JA2
(install jumpers as
shown below)**

BG-241

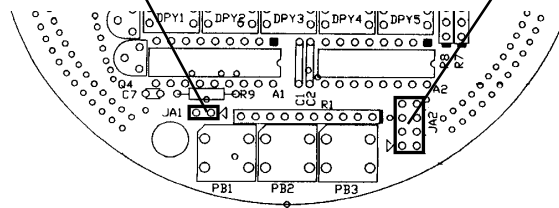

**Digital Flash Inhibit
(Digital Display only)**



**Over/Under Range Flash Inhibit
(Bar and Digital Displays)**



Lamp Test

Option 4 (Isolated Retransmit)

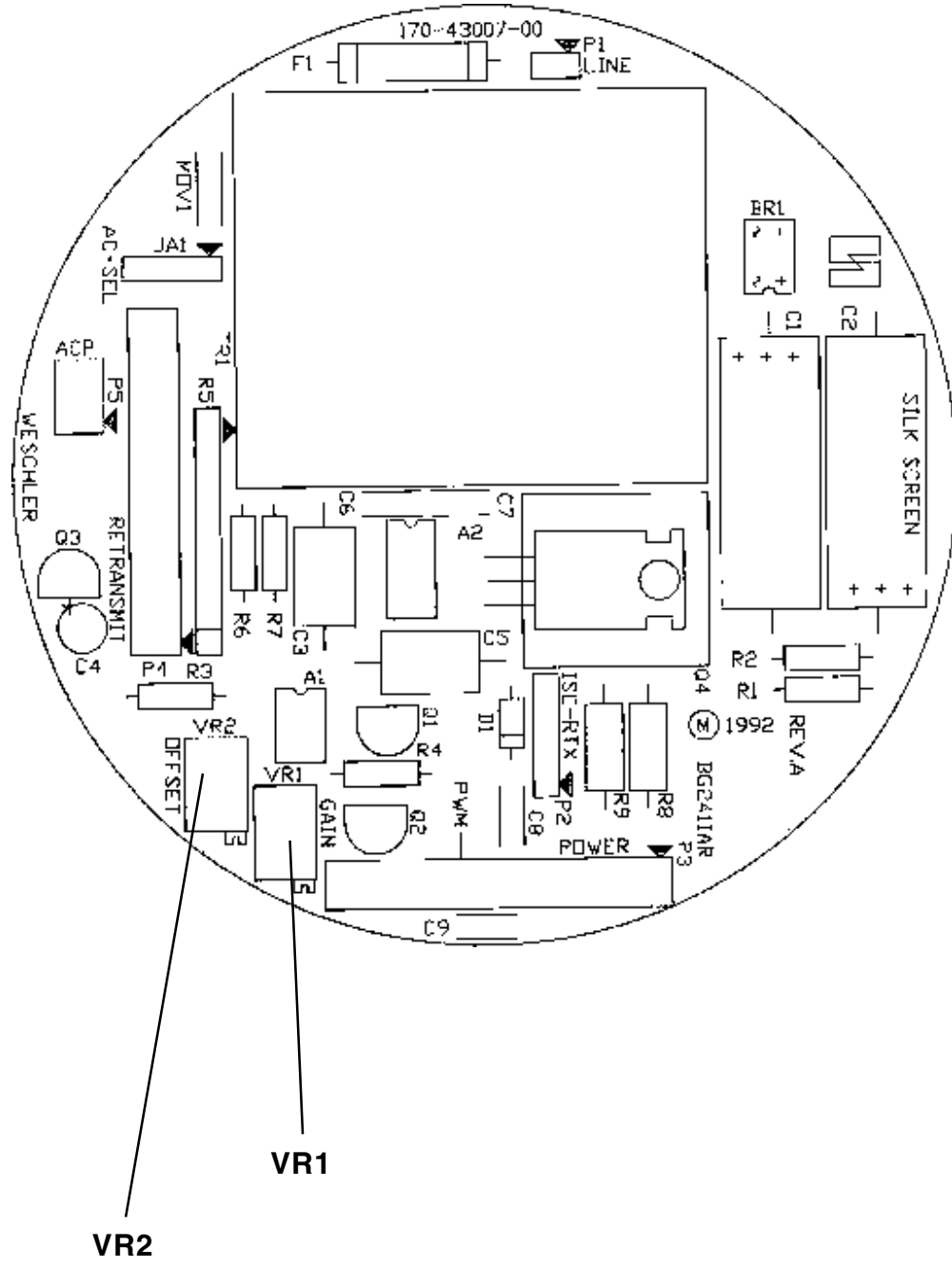

Appendix V - PHYSICAL DIMENSIONS

BG-241

A BG-241 has the following dimensions and recommended panel cutout:

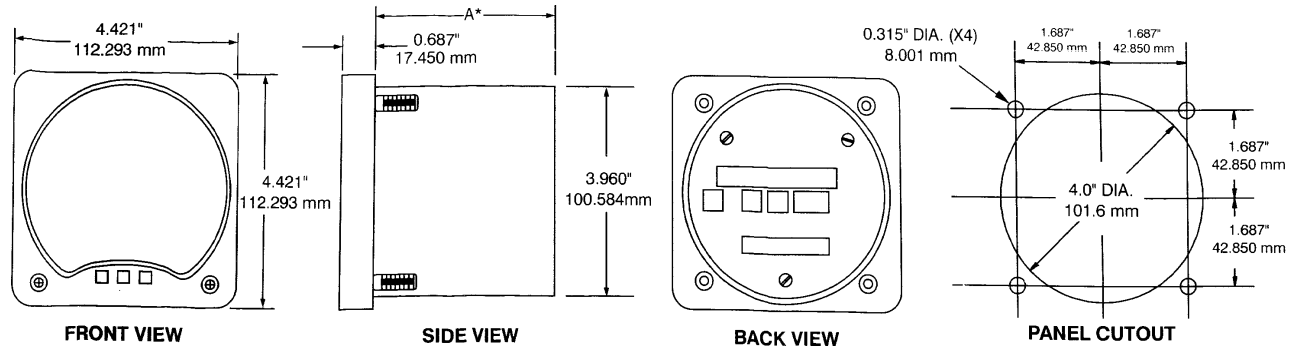

BG-261

A BG-261 has the following dimensions and recommended panel cutout:

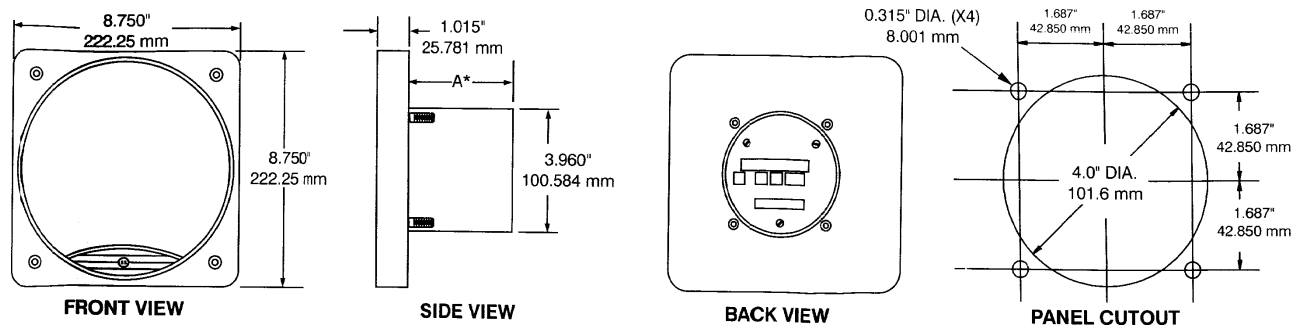

BG-251 and BG-281

A BG-251 or BG-281 has the following dimensions and recommended panel cutout:

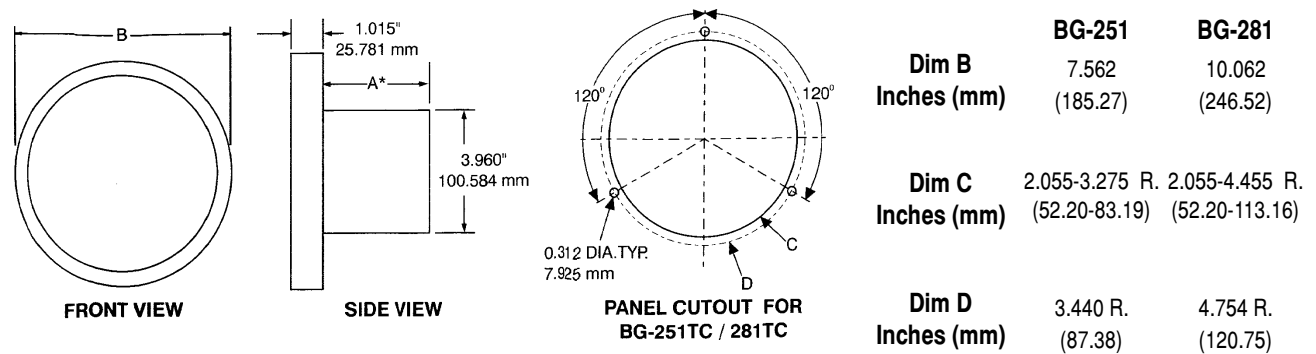

BG252

A BG252 has the following dimensions and recommended panel cutout:

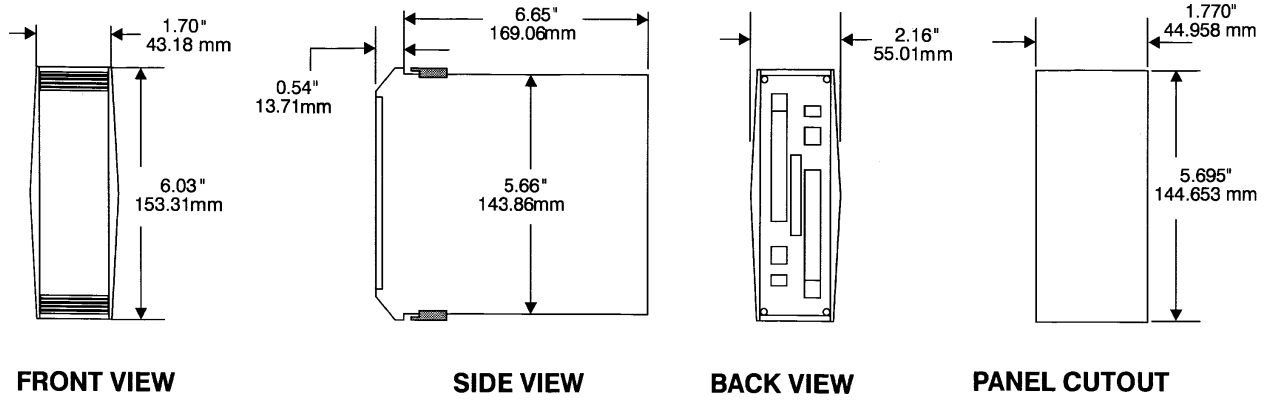

PC-101 and PC-202

A PC-101 or PC-202 has the following dimensions and recommended panel cutout:

