



Display Screens (3 Phase)

- 1: $V_{L1-N}, V_{L2-N}, V_{L3-N}$ (4-wire only)
- 2: $V_{L1-L2}, V_{L2-L3}, V_{L3-L1}$
- 3: I_{L1}, I_{L2}, I_{L3}
- 4: W, VAR, VA
- 5: PF, Hz
- 6: Active Energy (W.h, kW.h or MW.h)
- 7: Reactive Energy (VAR.h, kVAR.h or MVAR.h)
- 8: Avg. Demand W, A, VA
- 9: Peak Demand W, A, VA
- 10: THD V_{L1}, V_{L2}, V_{L3}
- 11: THD I_{L1}, I_{L2}, I_{L3}

FEATURES

- Measure 17 Electrical Parameters
- Rugged Metal Case fits Standard ANSI Hole
- Use on Single & Three Phase Systems
- Direct Input & Auxiliary Power to 480VAC
- RS-485 Modbus Communications

SYSTEMS

- Single Phase, 2 Wire
- Single Phase, 3 Wire
- 3 Phase, 3 Wire
- 3 Phase, 4 Wire

Each MD3000 is a complete digital power metering system in a standard ANSI switchboard case. Scroll the two front panel buttons to read voltage, current, power, demand and other system parameters. Use the MD3000 to monitor distribution feeders, branch circuits, generator sets, UPS systems and other power circuits. It easily retrofits into existing control panels with a standard 4" hole pattern. Monitor software allows remote setup and readings through the Modbus digital communications port.

PARAMETERS MEASURED

- Phase to Phase Voltage (V)
- Phase to Neutral Voltage (V)
- Phase Current (A)
- Frequency (Hz)
- Active Power (W)
- Apparent Power (VA)
- Reactive Power (VAR)
- Power Factor (PF)
- Instantaneous Demand Amp
- Instantaneous Demand Active Power
- Instantaneous Demand Apparent Power
- Maximum Demand Amps
- Maximum Demand Active Power
- Maximum Demand Apparent Power
- Total Harmonic Distortion - Phase Volts & Amps
- Energy (Wh, VAh, VARh)

SPECIFICATIONS

Voltage Input	120, 240, 277 or 480 VAC nominal	Case	Steel body, polycarbonate bezel
Range	20-120%	Weight	2.2 lb (1kg)
Burden	0.5VA per phase	Memory	Setup parameters stored in non-volatile memory
Overload	Continuous 1.5x nominal, 4x for 1 second	Security	Programming mode lockout via 4 digit code
Current Input	1A or 5A	Protection	Class I
Range	10-120%	Dielectric Withstand	3kV RMS @60Hz between case, input, Aux
Overload	Continuous 4x nominal, 50x for 1 second	Impulse	5kV transient per IEC801, EN55020
Frequency	45-65Hz	Surge	IEEE C37.90
Demand Interval	3-30 min. in 1 min. increments	Interference	EHF 2.5kV per IEC255-4
Accuracy:		EMI	EN50082/1 and EN50082/2
Volts & Amps	0.5% of reading ± 2 digits	Shock	30G in 2 planes
Frequency	0.1Hz ± 1 digit	Operating Temperature	-20°C to +70°C
Active Power	1% of reading ± 2 digits	Storage Temperature	-40°C to +85°C
Reactive Power	1% of reading ± 2 digits	RH	<95%, non-condensing
Apparent Power	1% of reading ± 2 digits	Warmup	1 minute
Power Factor	2% of range	Options:	
Energy	IEC 1036 class 1	Pulse Output	Ah, Wh, VAh, VARh
THD	1% of range	RS-232	SPNO contact; 50V, 150mA max programmable pulse width
Auxiliary Power		Communications	RS-485 2 wire
AC	120, 240, 277, 480 VAC $\pm 15\%$	Protocol	Modbus RTU
DC	45-65Hz, burden <7VA	Baud Rate	2400, 4800, 9600, 19200
DC	12, 24, 125 VDC $\pm 15\%$	Address	1 to 247
Display	3 lines of 4 digits, each 0.6" high		
Connections	Screw terminals for #22 to #14 AWG wire		

CONFIGURATION GUIDE

CONNECTION DIAGRAMS

MD3000 Configuration Guide

To Order - Specify model and configuration
 Example: MD3000-13156A1

MD3000 - **A** **B** **C** **D** **E** **F**

A Phase/Wire

- 12 **Single phase, 2 wire (1 element)**
- 13 **Single phase, 3 wire (2 element)**
- 33 **3 phase, 3 wire (2 element)**
- 34 **3 phase, 4 wire (3 element)**

B Input Voltage

- 1 **120V AC (line-neutral or line-line)**
- 2 240V AC (line-line)
- 3 277V AC (line-neutral)
- 4 480V AC (line-line)

C Input Current

- 1 1A AC
- 5 **5A AC**

D Frequency

- 5 50Hz
- 6 **60Hz**

E Auxiliary Power

- A1 **120V AC**
- A2 240V AC
- A3 277V AC
- A4 480V AC
- D1 12V DC
- D2 24V DC
- D3 125V DC

F Options

- P Pulse output
- R RS232 data streaming output (replaces RS485)

Most popular configuration choices shown in bold.
 Not all combinations available.

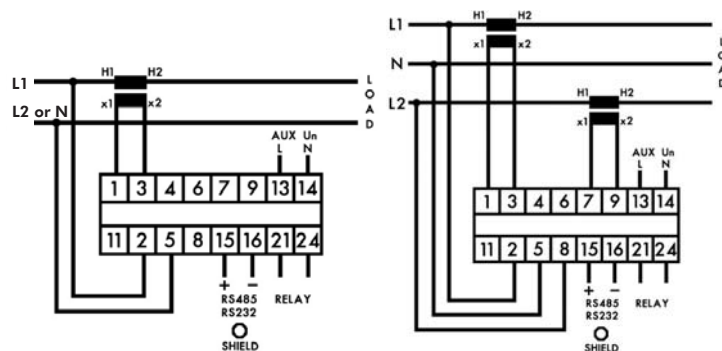

SINGLE PHASE 2 WIRE

SINGLE PHASE 3 WIRE

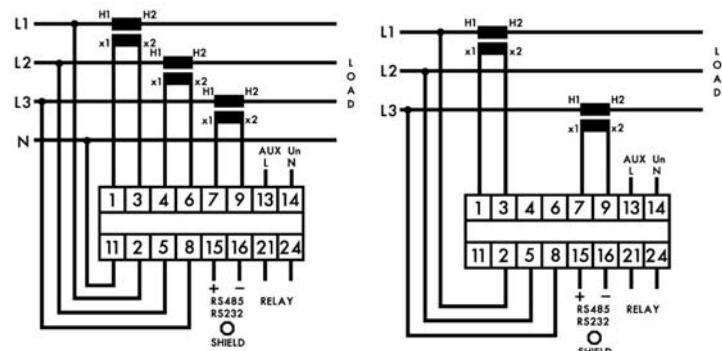

3 PHASE 4 WIRE
UNBALANCED LOAD

3 PHASE 3 WIRE
UNBALANCED LOAD

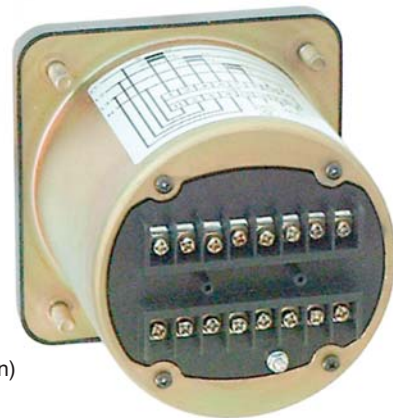

Steel case & screw terminal connections provide easy installation and reliable operation. (Terminal cover not shown)

CASE DIMENSIONS

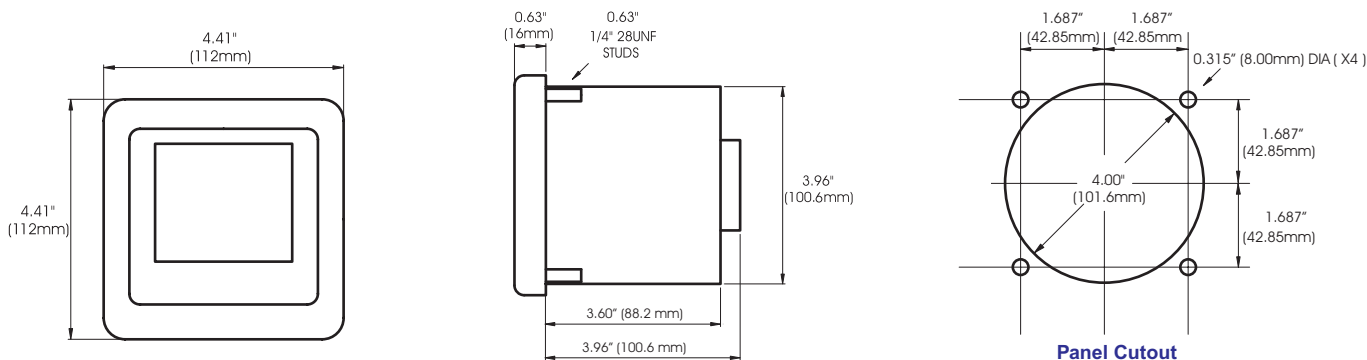

WD-06 2/06