

MODEL IAMS – INTELLIGENT UNIVERSAL SIGNAL CONDITIONING MODULE



- UNIVERSAL INPUT, PROCESS, mA DC, VDC, TC, 100 (RTD, POTENTIOMETER, AND LINEAR RESISTANCE)
- UNIVERSAL POWER SUPPLY, 21.6 to 253 VAC/ 19.2 to 300 VDC
- 3-WAY ISOLATION (POWER/SIGNAL/OUTPUT)
- CHOOSE SETPOINTS AND/OR ANALOG OUTPUT MODELS
- PROGRAMMING/DISPLAY MODULE (NOT INCLUDED)
- PROGRAMMING AVAILABLE IN SEVEN DIFFERENT LANGUAGES



GENERAL DESCRIPTION

The IAMS — Universal Signal Conditioners unmatched capability provides users the ultimate in flexibility. As a signal conditioner, the unit provides complete isolation and conversion capability to satisfy almost any application. The Universal Input accepts Process, DC Current, DC Voltage, Thermocouples, RTDs, Potentiometers, and Linear Resistance signals allowing the module to be connected to most common sensors. The setpoint model allows dual setpoint control capability through dual Form A relays. The analog model provides a retransmitted analog signal. A third model provides both analog and control capability. The power supply is also universal, accepting 21.6 to 253 VAC/ 19.2 to 300 VDC as its power source. Add the optional programming module and the unit is easily programmed through menu style programming. The module can also be used to provide a display of the process variable when it is not being used for programming.

The IAMS features well over 100 combinations of inputs to outputs configurations. Input specific terminals allow for the various signals and sensors to be connected to the unit while the input ranges and resolutions are adjusted in the input programming loop of the unit. The menu style programming allows the user quick and easy set-up by using the PGMMOD, programming module. The module is required to program the IAMS. However, if you are using more than

one IAMS, only one programming module is required. The module can store programming from one unit and load it to a second unit reducing set-up time for multiple installations. When the programming module is not being used for programming, it can indicate the input parameters, just like a panel meter.

The unit's overall full scale accuracy typically exceeds 0.1 % depending on the range selection and scaling. The microprocessor based design provides ease of field scaling and the onboard E²PROM stores scaling values for future recall. All units come factory precalibrated for all input and output ranges. Factory or custom field scaling can be selected in the Advanced programming loop. The IAMS can be factory recalibrated in the field if desired.

The unit's environmental operating temperature range is -20° C to 60° C. DIN rail mounting saves time and panel space. The units are equipped with mounting feet to attach to top hat profile rail according to EN50022 – 35 x 7.5 and 35 x 15.

SAFETY SUMMARY

All safety related regulations, local codes and instructions that appear in the literature or on equipment must be observed to ensure personal safety and to prevent damage to either the instrument or equipment connected to it. If equipment is used in a manner not specified by the manufacturer, the protection provided by the equipment may be impaired.

ORDERING INFORMATION

DESCRIPTION	PART NUMBER
Intelligent Universal Signal Conditioner with Analog Output	IAMS0001
Intelligent Universal Signal Conditioner w/Dual Setpoints	IAMS0010
Intelligent Universal Signal Conditioner w/Analog Output and Dual Setpoints	IAMS0011
Programming Display Module (Not Included) *	PGMMOD00

* At least one module is required to program a unit or a series of units.

DIMENSIONS In inches (mm)

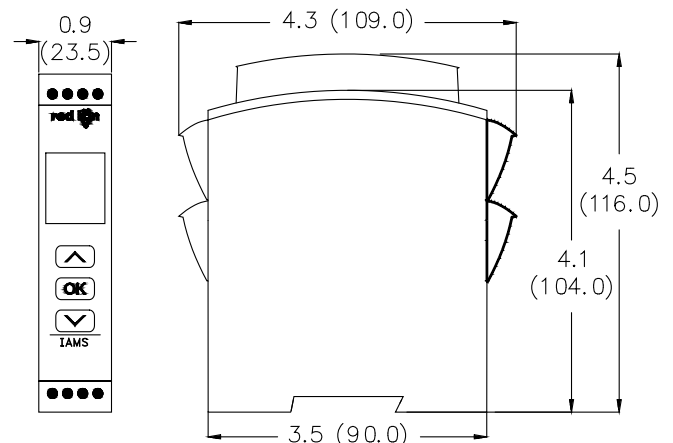

IAMS GENERAL SPECIFICATIONS

- 1. DISPLAY:** See Display/ Programming Module
- 2. POWER:**
AC Power: 21.6 to 253 VAC, 50/60 Hz
DC Power: 19.2 to 300 VDC,
- 3. CONSUMPTION:** ≤ 2.5 W
- 4. FUSE:** 400 mA SB/250 VAC
- 5. ISOLATION:** Between input, supply and outputs - 2.3 kVAC/250 VAC
- 6. INPUTS:**

Current Input:

Programmable Ranges: 0 to 20 and 4 to 20 mA DC
Measurement range: -1 to 25 mA
Input resistance: Nom. 20 Ω + PTC 50 Ω
Sensor error detection: 4 to 20 loop break, yes
Supply Voltage: 16-25 VDC, 20 mA max (Terminal 43 and 44)

Voltage Input:

Programmable Ranges: 0 to 1, 0.2 to 1, 0 to 5, 1 to 5, 1 to 10, and 2 to 10 VDC
Measurement range: -20 mV to 12 VDC
Input resistance: Nom. 10 M Ω

Thermocouple Inputs:

Thermocouple Type: B, E, J, K, L, N, R, S, T, U, W3, W5, and LR
Cold Junction Compensation: via internally mounted sensor $< \pm 1.0$ $^{\circ}\text{C}$
Sensor Error Detection: All TC types, yes
Sensor Error Current: When detecting 2 μA , otherwise 0 μA

RTD, Linear Resistance, Potentiometer Inputs

RTD Types: Pt10, Pt20, Pt50, Pt100, Pt200, Pt250, Pt300, Pt400, Pt500, Pt1000, Ni50, Ni100, Ni120, and Ni1000

INPUT TYPE	MIN. VALUE	MAX. VALUE	STANDARD
Pt100	-200 $^{\circ}\text{C}$	+850 $^{\circ}\text{C}$	IEC60751
Ni100	-60 $^{\circ}\text{C}$	+250 $^{\circ}\text{C}$	DIN 43760
Lin. R	0 Ω	10000 Ω	-
Potentiometer	10 Ω	100 k Ω	-

Cable Resistance per wire: RTD, 50 Ω max.

Sensor Current: RTD, Nom. 0.2 mA

Sensor Error Detection: RTD, yes

Short Circuit Detection: RTD, < 15 Ω

- 7. STEP RESPONSE TIME:** (0 to 90% or 100 to 10%)

Temperature input: ≤ 1 sec

Current/Voltage input: ≤ 400 msec

- 8. ACCURACY:** The greater of the general and basic values.

GENERAL VALUES		
Input Type	Absolute Accuracy	Temperature Coefficient
All	$\leq \pm 0.1\%$ of span	$\leq \pm 0.1\%$ of span/ $^{\circ}\text{C}$

BASIC VALUES		
Input Type	Basic Accuracy	Temperature Coefficient
mA	$\leq \pm 4$ μA	$\leq \pm 0.4$ $\mu\text{A}/^{\circ}\text{C}$
Volt	$\leq \pm 20$ μV	$\leq \pm 2$ $\mu\text{V}/^{\circ}\text{C}$
Pt100	$\leq \pm 0.2$ $^{\circ}\text{C}$	$\leq \pm 0.01$ $^{\circ}\text{C}/^{\circ}\text{C}$
Lin. R	$\leq \pm 0.1$ Ω	$\leq \pm 0.01$ $\Omega/^{\circ}\text{C}$
Potentiometer	$\leq \pm 0.1$ Ω	$\leq \pm 0.01$ $\Omega/^{\circ}\text{C}$
TC Type: E, J, K, L, N, T, U	$\leq \pm 1$ $^{\circ}\text{C}$	$\leq \pm 0.5$ $^{\circ}\text{C}/^{\circ}\text{C}$
TC Type: B, R, S, W3, W5, LR	$\leq \pm 2$ $^{\circ}\text{C}$	$\leq \pm 0.2$ $^{\circ}\text{C}/^{\circ}\text{C}$

- 9. CALIBRATION TEMPERATURE:** 20 to 28 $^{\circ}\text{C}$
- 10. RELAY OUTPUTS:** Dual Form A. Contacts rated at 2 A AC or 1 A DC
Hysteresis: 0.1 to 25 % (1 to 2999 display counts)
On and off delay: 0 to 3600 sec
Sensor Error Detection: Break / Make / Hold
Max. Voltage: 250 Vrms
Max. Current: 2 A AC or 1 ADC
Max. Power: 500 VA

TYPE	MIN. VALUE	MAX. VALUE	STANDARD
B	+400 $^{\circ}\text{C}$	+1820 $^{\circ}\text{C}$	IEC 60584-1
E	-100 $^{\circ}\text{C}$	+1000 $^{\circ}\text{C}$	IEC 60584-1
J	-100 $^{\circ}\text{C}$	+1200 $^{\circ}\text{C}$	IEC 60584-1
K	-180 $^{\circ}\text{C}$	+1372 $^{\circ}\text{C}$	IEC 60584-1
L	-200 $^{\circ}\text{C}$	+900 $^{\circ}\text{C}$	DIN 43710
N	-180 $^{\circ}\text{C}$	+1300 $^{\circ}\text{C}$	IEC 60584-1
R	-50 $^{\circ}\text{C}$	+1760 $^{\circ}\text{C}$	IEC 60584-1
S	-50 $^{\circ}\text{C}$	+1760 $^{\circ}\text{C}$	IEC 60584-1
T	-200 $^{\circ}\text{C}$	+400 $^{\circ}\text{C}$	IEC 60584-1
U	-200 $^{\circ}\text{C}$	+600 $^{\circ}\text{C}$	DIN 43710
W3	0 $^{\circ}\text{C}$	+2300 $^{\circ}\text{C}$	ASTM E988-90
W5	0 $^{\circ}\text{C}$	+2300 $^{\circ}\text{C}$	ASTM E988-90
LR	-200 $^{\circ}\text{C}$	+800 $^{\circ}\text{C}$	GOST 3044-84

11. ANALOG OUTPUT:

Current Output:

Signal Range (Span): 0 to 20 mA

Programmable Measurement Range: 0 to 20, 4 to 20, 20 to 0, and 20 to 4 mA

Load Resistance: 800 Ω max.

Output Compliance: 16 VDC max.

Load Stability: = 0.01 % of span, 100 Ω load

Sensor Error Detection: 0 / 3.5 mA/ 23 mA / none

Output Limitation: For 4 to 20 and 20 to 4 mA signals - 3.8 to 20.5 mA

For 0 to 20 and 20 to 0 mA signals - 0 to 20.5 mA

Current Limit: = 28 mA

Voltage Output:

Signal Range: 0 to 10 VDC

Programmable Signal Ranges: 0 to 1, 0.2 to 1, 0 to 10, 0 to 5, 1 to 5, 2 to 10, 1 to 0, 1 to 0.2, 5 to 0, 5 to 1, 10 to 0, and 10 to 2 V

Load: 500 K Ω min

12. ENVIRONMENTAL CONDITIONS:

Operating Temperature: -20 to +60 $^{\circ}\text{C}$

Operating and Storage Humidity: 95% relative humidity (non-condensing)

13. CERTIFICATIONS AND COMPLIANCES:

ELECTROMAGNETIC COMPATIBILITY:

EMC 2004/108/EC Emission and Immunity EN 61326

EMC Immunity Influence $\leq \pm 0.5\%$ of span

Extended EMC Immunity: NAMUR NE 21,

A criterion, burst $\leq \pm 1\%$ of span

SAFETY

LVD 2006/95/EC EN 61010-1

Factory Mutual Approved, Report #3034432, FM 3600, 3611, 3810, and ISA 82.02.01

FM, applicable in: Class I, Div. 2, Group A, B, C, D

Class I, Div. 2, Group IIC

Zone 2

Max. ambient temperature for T5 60 $^{\circ}\text{C}$

UL Listed, File # E324843, UL508, CSA C22.2 No. 14-M95

LISTED by Und. Lab. Inc. to U.S. and Canadian safety standards

Refer to the EMC Installation Guidelines section of this bulletin for additional information.

- 14. CONSTRUCTION:** IP 50/IP20 Touch Safe, case body is black high impact plastic. Pollution Degree 1.

- 15. CONNECTIONS:** High compression cage-clamp terminal block. Use 60/75 $^{\circ}\text{C}$ copper conductors only.

Wire strip length: 0.3" (7.5 mm)

Wire gage: 26 - 14 AWG stranded wire

Torque: 4.5 inch-lbs (0.5 N-m) max

- 16. WEIGHT:** 5 oz (145 g)

5.6 oz (160 g) with programming module